



Approved by the government of Tbilisi City
on 28 March 2011 Decision No. 07.10.237

Sustainable Energy Action Plan City of Tbilisi For 2011- 2020



TBILISI 2011

Contents

Introduction – Covenant of Mayors and City of Tbilisi.....	- 4 -
Strategic Vision	- 6 -
1. Transport Sector	- 9 -
1.1. Current Situation and Future Trends.....	- 9 -
1.2. Baseline Emissions Inventory for Transport Sector	- 23 -
1.3. Action Plan Table for Tbilisi Transport Sector.....	30
1.4. Description of Actions.....	33
2. Building Sector	39
2.1. Current Situation and Future Trends.....	39
2.1.1. Energy Consumption Analysis of Buildings	40
2.2. Baseline Emissions Inventory.....	57
2.2.1. Energy End Use Technologies, Consumption Trends and Analysis for Calculation of CO ₂ Emissions	58
2.2.2. Household Baseline Inventory and BAU Scenario Development	72
2.4. Buildings Sector General Strategy for Reducing Greenhouse Gas Emissions in the City.....	77
2.4. Action plan in buildings sector.....	81
2.5. Description of Energy Efficiency Measures in the Buildings Sector for the Period 2011-2020	85
3. Street Lighting Sector.....	98
3.1. Current Situation and Future Trends.....	98
3.2. Street Lighting Baseline Inventory and BAU Scenario Development.....	99
3.3. Action Plan Table for Street Lighting Sector	103
3.4. Description of Actions.....	103
4. Municipal Landfills	105
4.1. Current Situation and Future Trends.....	105
4.2. Baseline Emissions Inventory for Municipal Landfills	109
4.3. Action Plan Table for Municipal Landfills.....	117
4.4. Description of Actions.....	118
5. Waste Water Treatment	120
5.1. Current Situation and Future Trends.....	120

5.2. Baseline Emissions Inventory for Waste Water Treatment	122
5.3. Action Plan Table for WWT	128
5.4. Description of Actions.....	129
6. Green Spaces.....	130
6.1. Current Situation and Future Trends.....	130
6.2. Baseline Emissions Inventory for Green Spaces.....	133
6.3. The Action Plan Table for Green Spaces	135
6.4. Description of Actions.....	137
7. Electricity Distribution	138
8. Gas Distribution	138

Introduction – Covenant of Mayors and City of Tbilisi

At the Covenant of Mayors conference, held in Tbilisi in October 2010, the important role of cities as complex systems having a large capacity to fight greenhouse gas emissions was stressed. Municipalities have been identified as a main driving force in guiding the development and implementation of the Sustainable Energy Action Plan (SEAP) within EU energy efficiency priorities.

In 2010, by signing the Covenant of Mayors, **Tbilisi City Hall** joined an initiative under which Tbilisi should become a “**low carbon city**” by 2020 - a goal that will be reached through the support of social and economic development of the city.

In order to achieve this goal, the Tbilisi City Hall elaborated on the **Sustainable Energy Action Plan for Tbilisi**. The process of development of the SEAP implied

- development of an overall strategy for the reduction of energy consumption in the capital
- development of a Baseline Emissions Inventory (BEI) for Tbilisi
- development of a sustainable energy action plan with selected energy efficiency measures for the period until 2020
- acknowledgement of the role of Tbilisi City Hall as the main administrative driving force in carrying out responsibilities addressing all activities related to energy consumption and use of renewable energy in transport, buildings and municipal infrastructure sectors that can't be implemented without municipality support
- raising public awareness by promoting information about the application of energy saving measures.

Fast economic development of Tbilisi, the population growth rate and increasing GDP per capita were taken as main assumptions while developing the reference scenario for 2020 and planning the concrete measures in order to decrease the energy consumption and CO₂ emissions of the city. **In case, the actions proposed in the SEAP are implemented, the overall CO₂ emissions in Tbilisi will be reduced 25% by 2020.**

City of Tbilisi – Brief Overview

Tbilisi, the capital of Georgia, represents a significant industrial, social and cultural centre not only in Georgia, but in Eastern Europe and the Caucasus region. Situated along the route of the historical Silk Road, Tbilisi still holds a strategic location at the crossroads of Russia, Turkey, Armenia and Azerbaijan, Europe and Asia, and the Islamic and Christian worlds. Georgia is now emerging as one of the most important transit countries for the flow of global energy, information and trade.

The city stretches 33 km along the Mtkvari River and covers an area of 372 square km. The river divides the city into two parts, with the left side of the city exceeding the right in both territory and population. The southeast part of the city is 350 meters above sea level, while the populated areas of the Mtatsminda slope are located at 550-600 meters above sea level.

In January 2010, there were an estimated **1,152,500 people** living in Tbilisi, which is almost 30% of Georgia's total population. The growth rate of the population in the past ten years has been **1.1%**. According to 2005 calculations, the population density in Tbilisi is 2,937 persons per square km. The densest region is the Didube- Chugureti district with 7,855 persons per square km, and the lowest density is in the Isani-Samgori district with 2,323 persons per square km.

Following the political turmoil in Georgia and its capital at the end of the 1990s that nearly brought the economic and social system to a collapse, the main economic indicators have been improving since 2001. Thanks to a complex of socio-economic reforms undertaken, **GDP growth** in Georgia has been brisk since 2003. In 2005, annual per-capita GDP in Tbilisi was 2,732 GEL, which is about 170 GEL, or 6.5%, more than Georgia as a whole. A significant portion of this economic growth can be explained by the ongoing economic activity of Tbilisi. Industrial output in the capital in 2005 increased by 501.5 million GEL and reached a total of 2,731.8 million GEL, which represented 53.8% of Georgia's total industrial output. The production of goods and provision of services in Tbilisi differs in legal forms from the overall tendency existing in Georgia. The share of the nongovernmental sector in the capital is about 10% higher than in the rest of the country and accounts for 84% of Georgia's total output. Tbilisi's economy is based on the fields of industry, transport and communication, which in aggregate represent more than a half of the output of the capital city.

Strategic Vision

The main objective of the Sustainable Energy Action Plan for Tbilisi is to reduce CO₂ emissions caused by city energy usage. In addition, the number of natural sources of CO₂ emission absorption, such as forest areas surrounding the capital as well as parks within the city, will grow and develop. In conjunction to the Covenant of Mayors, Tbilisi City Hall aspires to make Tbilisi the “Green Capital” of the South Caucasus.

While implementing the SEAP for Tbilisi, it will be essential to preserve the cultural and historical heritage and identity of the city, to involve all interested parties (private, public, city government) into the planning and implementation process of the Plan, to raise awareness/change behavior of citizens, especially while introducing new carbon technologies in the energy consumption sector.

In June 5, 2009 the Tbilisi City Council adopted a **Strategic Plan for Future Development of the Capital City** (thereafter called the Strategic Plan of Tbilisi). The SEAP and elaborated strategy for reduction of greenhouse gas emissions (GHGs) sources on the territory of the city fully incorporate the priorities identified in the Strategic Plan of Tbilisi. Among these priorities are: the development of the transport sector (chapter VIII), improvement of electricity (chapter IX, article 15) and heating (chapter IX, articles 17&18) supply in the city, development of other infrastructure such as water supply (chapter IX, article 11) and municipal sewage system (chapter IX, article 12). The chapter on Landscape Environment and Development (chapter VII) focuses on the development of green spaces that will result in an increased number of sources for absorbing CO₂ emissions in the city territory. Though the Strategic Plan of Tbilisi has no list of concrete actions that will support the growth of CO₂ emissions absorption sources, it does provide a general vision that is translated into concrete activities under the SEAP.

Since 2005, the rehabilitation of existing and construction of new urban infrastructure has been underway in Tbilisi. In particular, the capacity of transport infrastructure has been increased, which has resulted in enhanced traffic flow. The construction sector has become a major contributor to the development of the local economy, but at this point they have no significant energy efficiency measures in use. The outdoor lighting sector has significantly grown and has become energy intensive. As a result, the amount of GHGs from these sectors has increased significantly. According to the Strategic Plan of Tbilisi, considerable grow of the city population is not expected, but within the agglomeration policy a territorial expansion of the city is planned that will result in an increased number of mobile and static sources of CO₂ emissions.

At this stage **three main energy sectors have been discussed in the SEAP of Tbilisi – transport, buildings, and infrastructure (municipal waste and waste water management treatment, street lighting, electricity and gas distribution networks, and green spaces).** Based on the **Baseline Emission Inventory (BEI) for 2009** and the **projection of the increase in CO₂ emissions by 2020**

conducted within the framework of the Tbilisi SEAP, strategies and main actions for each sector were elaborated:

Transport Sector:

According to the BEI of 2009, the major source of CO₂ emissions in Tbilisi is from the local transport sector. **A rehabilitation and development of transport infrastructure was identified as the short-term strategy (2011-2015)** for the sector that comes in full accordance with the Strategic Plan of Tbilisi (chapter VIII and chapter IX, article 20). It will result in a partial decrease of CO₂ emissions from the transport sector.

The **mid-term strategy (2012-2018) is to increase the share of public transportation within a total passenger turnover**. Special attention will be paid to the development of an electric transport network since the energy intensity of electric transport (such as tram and subway) per passenger per kilometer is much better compared to other modes of public transport. Also, it is envisaged that in the future the emission factor of electricity will decrease significantly due to national government plans to significantly increase its hydropower generation share in the electricity generation sector.

The **long-term strategy (2018-2020) of the transport sector aims at decreasing the mobility of private cars and encouraging low emission cars by means of various restrictions and incentives** (it is implied, that this will happen by the time the public transport and street infrastructure is well developed and meets society's need in terms of speed, convenience and accessibility).

Building Sector

The Strategic Plan of Tbilisi identifies several energy efficiency measures to be carried out. Among them are a reduction of electricity distribution losses, energy efficiency measures for the water supply system, a reduction of heat distribution losses in municipal and public buildings, efficient metering, and a reduction of gas distribution losses. However, no special attention is paid to the building sector and energy efficiency measures within the sector.

In the SEAP of Tbilisi the building sector is identified as the second largest emitter of GHGs after the transport sector. The heat sub-sector has been identified as having a very serious potential of GHG emissions reduction. Within the **short-term strategy (2011-2015) the plan is to increase efficiency of heating systems and the share of renewable energy in the heating (geothermal energy, biomass and solar energy) sub-sector within the municipal building stock (kindergartens, polyclinics).**

The **mid-term strategy (2014-2017) plans to apply the same measures to public buildings that are not under administration of the Tbilisi Municipality (schools, state agencies etc); while in the long-term strategy (2015-2020) energy efficiency will be increased, and the share of renewable**

energy in heating will grow in the residential building stock. Other energy efficiency actions will be carried out as well.

The objectives for the building sector of the SEAP include:

- improving thermal properties of building stock
- changing existing energy consumption practices
- creating an enabling environment for the implementation of all the above measures
- increasing the share of renewable energy sources in heat supply
- reducing energy expenditures in all categories for consumers in buildings
- achieving average energy consumption and utilization patterns which are in line with the minimum EU standards.

Municipal Infrastructure Sector

The strategy for municipal infrastructure covers six sub-sectors and aims at capturing methane (CH₄) from municipal landfills (closed as well as new ones) and waste water treatment plants, burning or using captured methane as an energy source, increasing energy efficiency and the share of renewable energy in the outdoor lighting sector, and developing green spaces throughout the city.

Georgia is a Non-Annex 1 country under the UN Framework Convention on Climate Change (UNFCCC) and does not have a binding commitment to reduce CO₂ emissions. However, more than once the country has showed enthusiasm for making voluntary commitments if supported by developed countries. In the first and second National Communications of Georgia to the UNFCCC¹ a strategy for GHG emissions reduction from the energy sector is presented, but the country has not taken responsibility for its implementation thus far. In this context, the SEAP of Tbilisi should be considered as the first real step towards reducing GHG emissions on a voluntary basis. One-third of all Georgian emissions come from Tbilisi. Therefore, the concrete activities implemented by the Tbilisi Municipality will considerably contribute to a reduction of total emissions. Also, Tbilisi will become a positive example for other cities of Georgia and other Non-Annex 1 countries of the Convention.

¹ Georgia's National Communication to the UNFCCC. 1999 and 2009

1. Transport Sector

1.1. Current Situation and Future Trends

Tbilisi, the capital city of Georgia, is the most populated urban settlement in the country. According to data from the National Statistics Service of Georgia, by January 2010 the number of inhabitants of the capital was 1,152,500, which is almost 30 percent of the total population of the country (4 436.4 thousand persons as of January,1 2010)². Due to an increased number of urban populations, the transport fleet in Tbilisi has progressively grown, resulting in excess CO₂ emissions from the transport sector and other side effects, such as traffic congestion, loss of green areas, polluted local environment/ambient air, and excessive noise. If in 1991 the contribution of transport **to total emissions (including GHG emissions) in Tbilisi** was 70%, in 2005 the sector became responsible for about 91% of air pollution.³ According to the Second National Communication of Georgia to UNFCCC, in 2000 CO₂ emissions from the transport subsector amounted to 1,111.9 Gg, accounting for 35.0% of CO₂ emissions from the energy sector, 30% of total CO₂ emissions, and 10.1% of national GHG emissions. The major source of CO₂ emissions in this subsector was road transport, which emitted 1,052.9 Gg CO₂, accounting for 94.7% of CO₂ emissions from the transport subsector in 2000.⁴ It should be noted, that these figures account for the whole country, but at the same time present valuable information to make certain assumptions regarding the emissions from transport sector within the capital.

The current and future potential problems of the Tbilisi transport sector are partially related to a specific urban morphology of the city. Tbilisi has a linear shape and has developed along the main longitudinal vector with double parallel barriers – a natural one - the river Mtkvari, and an artificial one - the railway. These barriers prevent a smooth operation of the fleet of vehicles, creating a series of urban borders to cross and hindering the dispersion of air pollutants. The capital is surrounded by numerous hills that prevent the transport mobility even more.

² http://www.geostat.ge/?action=page&p_id=472&lang=geo

³ Sustainable Transportation in Tbilisi: current challenges and a way forward. Presentation by Mikheil Tushishvili

⁴ Georgia's Second National Communication to the UNFCCC, 2009

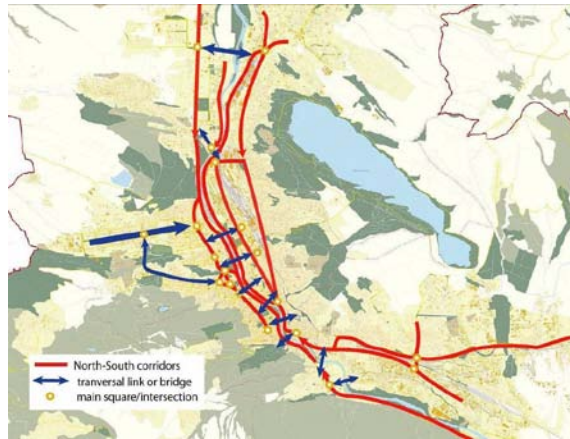

Source: Sustainable Urban Transport Project. Road Map by SYSTRA

The main traffic fleet is concentrated in the city centre – in the districts of Vake, Vera, Mtatsminda, Didube, and Saburtalo. The city has several structural avenues and a big number of secondary streets. The surface conditions of parallel roads in the city still remain to be of low quality and most of them are quite narrow, which often results in a disrupted vehicle flow. Even during Soviet times, though served by around 1,200 buses and electric transport facilities (trolley, underground, tram), Tbilisi was among the most polluted cities of the Soviet Union due to emissions from transport and heavy industry. In the early 1990s, after the collapse of the Soviet Union and decline of economic activities, the contribution of the transport sector to the total emissions of air pollutants decreased. However, from 1993 the transport sector started to recover and the air pollution in urban areas deteriorated again. The composition of the Tbilisi transport sector totally changed – the city government could not maintain stable public transport services, therefore private operators were allowed to offer alternative transportation means to local commuters. The city was covered with a large number of minibuses that were fast, flexible and affordable. Due to an energy crisis, the use of electric transport declined and bus services became inefficient. The number of private vehicles, especially secondhand cars from abroad, increased. The city suffered from traffic jams and serious air pollution⁵.



Picture 1: Traffic jams in Tbilisi. Source: Sustainable Transportation in Tbilisi: current challenges and a way forward. Presentation by Mikheil Tushishvili.

⁵ EBRD Financed Tbilisi Transport Project. http://bankwatch.org/documents/EBRD_transport_tbilisi.pdf

Transport infrastructure

After 2003 the Tbilisi City Hall implemented a number of projects that aimed at the improvement and development of transport infrastructure and management system. An extensive **rehabilitation of Tbilisi roads** has been carried out. The municipal budget expenditure allocated and spent to improve road conditions reached GEL 82.3 million in 2005, GEL 86.7 million in 2008, and GEL 111.6 million in 2009.⁶ So-called “Triangle” routes were set up permitting traffic in one direction on Varaziskhevi and Meliqishvili Streets that were among the most congested areas. In 2010 construction of the Vere River Highway began, offering direct access to the Vake and Saburtalo districts by bypassing the bottleneck created from the congestion on Chachavadze Avenue.⁷ The new highway reduced the flow of vehicles at Pekini Avenue as well. Instead of 2400 cars, the traffic flow was decreased to 2100 vehicles per hour.⁸

In addition to the rehabilitation and construction of the road network, as its priority the Tbilisi City Hall set to **increase the capacity of transport infrastructure and reduce traffic congestion through marking, an efficient crossroad and traffic lights system, and an improved city parking scheme.**



Picture 2: A new traffic light system on the crossing point of Beliashvili and Chachava streets. Source: www.tbilisi.gov.ge

A so-called ‘Green Wave’ system was introduced at Pekini Avenue, allowing for an uninterrupted stream of vehicles through six intersections. Before, around 2100 cars (per hour) had to stop at four out of six different intersections. Now after the introduction of a new system, around 800 cars have to stop only at two intersections, thus increasing the speed of the traffic flow and reducing the amount of fuel used by vehicles (approximately 1920 liters less per day).⁹

⁶ http://tbilisi.gov.ge/index.php?lang_id=GEO&sec_id=174

⁷ Challenges and possible solutions for sustainable urban transport in Tbilisi. Workshop on Sustainable Urban Transport and Land Use Planning. 18 -20 October 2006, Tbilisi, Georgia.

⁸ Information obtained from the Municipal Transport Unit. Tbilisi City Hall

⁹ Information obtained from the Municipal Transport Unit. Tbilisi City Hall

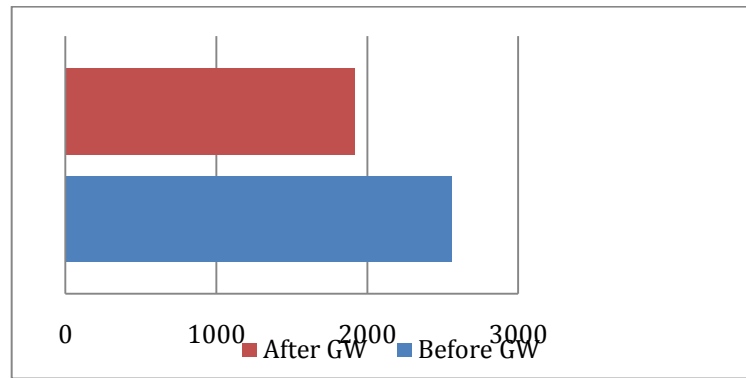

Figure 1: Reduction in fuel consumption after the introduction of the Pekini Green Wave System (litres per day). Source: Municipal Transport Department, 2011

In the near future the Green Wave system will be introduced at Budapeshti and Vazisubani streets and near the metro station “Isani”. The Tbilisi municipality will create a Traffic Lights Management Centre that will ensure efficient traffic light electronic management throughout the whole city.

In 2007, the City Council approved a new **parking system** for Tbilisi and designated special parking areas. By 2010, there were approximately 11,600 approved parking spaces¹⁰. In close collaboration with the Patrol Police, the city government sets the parking lots and controls unofficial parking. However, due to a large traffic volume, lack of official parking areas, and inappropriate driving habits, random street-side parking still prevails. The Municipality can either operate the parking system management through its municipal division or outsource it. Currently a private company, City Park, manages the Tbilisi parking system. The Tbilisi Municipality establishes parking fees and/or fee ranges, but the private operator can set parking fees within the municipal range based on factors like the time of the day, location, or the day of the week. Currently, the official parking fee – 25 GEL per year and 2 GEL per week for residential parking – was set by the Municipality. There are several secured parking lots where overnight parking costs 2 GEL. In the near future City Park might introduce a diversified parking pricing system. In addition, more outdoor and off-street parking places are planned for development in the city.¹¹ It should also be noted that according to existing requirements by the city municipality, every newly constructed multi-store residential and commercial building must provide an underground parking area that significantly improves the parking practice in the city.

¹⁰ Draft of the Road Map of Georgian Sustainable Urban Transport Project. SYSTRA. 2010

¹¹ The idea of construction of an off-street parking area is under development and negotiation with EBRD.

Urban Transport Composition

Two main types of vehicle fleet of the Tbilisi transport sector are described and analysed under the current SEAP document:

- Urban public
- Private
- Municipal fleet

According to the SEAP Baseline Emissions Inventory for 2009, Tbilisi city commuters travelled 7544 million passenger-kilometers in total, 73% of which was travelled by private cars and 27% by public transport. Within the public transport about 50.3% of the mobility was provided by minibuses, 25.1% by busses and 24.6% by subway. The graph below shows the split between modes of transport used in Tbilisi in 2009:

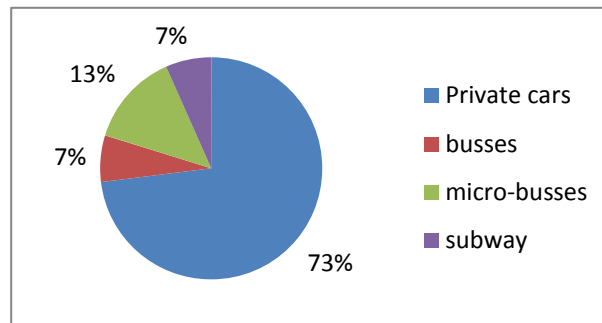

Figure 2: Split of transport modes in Tbilisi. BEI 2009

Public Transport

Bus, metro and minibus networks compose the current urban public transport fleet of Tbilisi. During the last few years serious efforts were made to make **public transport services** more attractive, reliable, and affordable for citizens. The number of passengers using bus and metro services significantly increased, but the minibus sector remains strong and the most popular means of public transportation.

As already shown above, the minibus system still has the highest number of passengers:

- roughly 260,000 for the Metro (Metro Company, 2009)
- roughly 215,000 for the bus network (Bus Company, 2009)
- roughly 430,000 for the minibus network (SYSTRA estimate, 2010)¹²

In 2006, new “**Yellow Busses**” were imported from Ukraine and Netherlands. The new bus services slowly gained popularity and the trust of citizens, so the number of buses running in the

¹² Draft of the Road Map of Georgian Sustainable Urban Transport Project. SYSTRA. 2010

capital city regularly increased – 489 buses in 2006, 569 buses in 2007, 791 buses in 2008 and 934 buses in 2009.¹³ The average age of these imported vehicles is 7 years.



Picture 3: Tbilisi Yellow Buses; Source: www.tbilisi.gov.ge

According to the SEAP BEI for 2009, the bus fleet was composed of three different types of diesel-running busses including 240 vehicles with fuel consumption of 55 liters per 100km, 150 vehicles with fuel consumption of 38 liters per 100km and 544 vehicles with fuel consumption of 24 liters per 100km. In total the busses have covered 58.4 million kilometers and served 56.9 million people, including 4 lines (88, 61, 51 and 21) with daily boarding of over 5,000 riders.¹⁴ In 2010, the city government decided to optimize the bus fleet and reduced the number of bus lines from 125 to 92 that automatically resulted in a decrease of buses running in the city. The quality of the existing bus network services suffer the lack of regularity of bus lines, lack of information for passengers on routes and time schedules, long waiting intervals, lack of route connections, overcrowded buses, and lack of comfort in the cabins.

The Tbilisi Metro system is the second most widely used public transport mode in the city. It has two main lines – Line 1 (red line) and Line 2 (blue line), with 27 km of double-track and 22 stations. The current metro fleet in operation is composed of 170 vehicles and the average age of rolling stock is 25 years old.¹⁵ The attractiveness of the underground network is gradually increasing due to the fact that it is fast (headway is 4 minutes at peak hours and about 5-6 minutes during off-peak hours), the network connections are good, the fee is affordable, and traveling is quite comfortable. In recent years a number of underground stations have been undergoing renovations and a great maintenance operation is currently in progress for the rolling stock in order to make it more comfortable and attractive for passengers. There are areas

¹³ Information obtained from the Municipal Transport Department. Tbilisi City Hall.

¹⁴ Draft of the Road Map of Georgian Sustainable Urban Transport Project. SYSTRA. 2010

¹⁵ Draft of the Road Map of Georgian Sustainable Urban Transport Project. SYSTRA. 2010

in the city where the underground network has not yet been constructed or developed. Therefore the citizens living, working, or commuting in those parts of Tbilisi are limited in public transport options. In the foreseeable future, the Metro Line 2 will be extended an extra 1.5 km and a new University Metro Station will be opened that will significantly relieve pressure on the road network. The construction of the tunnel to the University station started in the 1980s and has almost been completed. As one of the measures of SEAP this station will be finished. It is expected that the extension will add 4.4 million passengers per year to the metro network.¹⁶ The investment cost of the project is 30 million USD that will be provided by the Asian Development Bank (ADB) as a loan to the municipality.

The Minibus network offers quick and stop-on-demand transport in almost all parts of Tbilisi. In 2006, the Tbilisi Municipality banned minibuses from the main streets and till today they run only on parallel streets and avenues. The relocation of minibus routes helped to ease the mobility of daily fleets of vehicles on central streets, but environmental problems of the city remained the same. The minibus fleet of 2009 was composed of 2621 vehicles¹⁷. The minibuses operate on diesel and average fuel consumption is 12 liters per 100 km. On average minibuses travel 220 km daily and the passenger turnover is approximately twice as much as for bus network. The vehicles used by minibus companies are more than 20 year-old obsolete cars. According to the future plans of the city government, the minibus fleet will be renewed and extended as a part of SEAP. Instead of 188 minibus lines, there will be approximately 226 lines served by 2464 minibus cars.¹⁸ It is considered that the minibus vehicles suit the morphology of Tbilisi the best. They can move around the narrow streets of the capital, while it is challenging for buses to run through them. The first portion of new minibus fleet (350 vehicles) will be introduced in the city in May 2011 and the process will be finished in February 2012. The minibuses will be operated by four private companies – Tbil-Line Ltd., Capital Group Ltd, Tbil-car Ltd and Public-car Ltd.¹⁹ However, the Municipal Transport Unit of the Tbilisi City Hall reserves the right of regular (daily) monitoring of technical, quality and safety conditions of the minibus fleet operation. The Municipal Transport Unit will be the agency responsible for planning, monitoring and controlling the minibus lines.

¹⁶ Draft of the Road Map of Georgian Sustainable Urban Transport Project. SYSTRA. 2010

¹⁷ Information obtained from the Municipal Transport Department. Tbilisi City Hall.

¹⁸ The total number of new minibus fleet will be 3078 vehicles, however only 2464 cars will operate daily. Information obtained from the Municipal Transport Department. Tbilisi City Hall.

¹⁹ These private companies are the winners of the tender offer announced by the Tbilisi City Hall. A special commission was created to run the tender and reveal the winners. The companies were given the right to operate the minibus fleet for 20 years.



Picture 4: Minibus model that will serve the city from summer 2011. Source: <http://new.tbilisi.gov.ge>

In 2008, the Tbilisi City Hall introduced an efficient **ticketing system** for bus and metro services. Commuters top-up a plastic card with a certain amount of money that can be used while traveling either by bus or in the metro. In the case that a commuter changes several bus lines and uses the same card for payment for bus ticket in one day, the payment fee decreases. In addition, special discounts are offered to pensioners, socially vulnerable people, and students. The only problem concerning the electronic payment system is a lack of top-up services on the bus stops and throughout the city²⁰.

As one of the measures of the SEAP to increase the attractiveness of public transport, the same ticketing system – plastic card payment – will be introduced in new minibuses and better top-up services will be provided. Different pricing schemes will also be applied. In the first stage, the special discount fees will be provided to socially vulnerable people. In the coming future the plan is to make special discount offers to pensioners, students, as well as frequent travelers. Private companies will provide the electronic ticketing system in minibuses while the Municipal Transport Unit will monitor and control the process.

The tram and trolleybus network was well developed and widely used during Soviet times. After gaining independence, due to an energy crisis, the electric transport system in Georgia declined and could not offer regular services to passengers. However, these modes of transportation maintained popularity among its citizens. In 2006, by the decision of the Tbilisi City Hall, the tram and trolleybus system was abolished and removed. However, as a part of SEAP measures, the tram network will be reintroduced and promoted as an eco-friendly means of transportation. In 2010, the Tbilisi municipality contracted the consulting company SYSTRA to conduct a feasibility study and develop a design for the Tbilisi tram network. Currently it is known that the tram line is planned to be around 16 km long and connect Delisi and Samgori. There will also be a 23-kilometer line connecting Didi Digomi and Samgori as well as a 15-kilometer line connecting the city centre to the Saburtalo universities district. The latter route will go through Rustaveli and Chachavadze avenues. It is expected that the tram network will be finished by 2014. As a long-term objective, the tram network will be extended to the airport and in the direction of Gldani and Digomi districts. SYSTRA plans to present the final project by the end of

²⁰ Nowadays the cards can be topped-up at every metro station and in several banks.

2011.²¹ The project will be financed partially by a loan from the Asian Development Bank (ADB) and the municipal budget.

The same company, SYSTRA, is currently conducting a household survey among the inhabitants of Tbilisi to find out the current attitude towards different means of public transport (including alternative modes of public transport) and public transportation in general. The results of this survey will be known by the end of 2011.

Private Vehicles

As mentioned above, due to population growth, an increase in GDP, and a lack of efficiency in the public transport system the number of passenger cars has progressively grown. In 2000, the average car ownership was about 80 vehicles for every 1000 inhabitants; in 2005 it increased to 100 vehicles per 1000 inhabitants.²² In 2009, the fleet of passenger vehicles (including taxis) consisted of 233,187 cars.²³ In addition to a big number of vehicles, the poor quality of private cars contributes to increased transport related environmental stress to the city.

Big size cars (i.e. SUVs) are extremely popular among the population. No official statistics on the mobility by passenger cars is available. The surveys and expert knowledge were used to estimate passenger mobility in this sector. A survey conducted by SYSTRA shows the average car occupancy is about 1.85 people per car, which is quite low. The abundance of heavy cars and unmanaged road/traffic network leads to the assumption that average fuel consumption by a private car is 12 litres per 100 km while it is estimated that the average distance travelled per day is 35 kilometers.

Since there are no restrictions on the age of vehicles on the road, the number of second-hand European cars has significantly increased. By 2009, 41% of vehicles were 20 years old or older.²⁴ The catalytic converters are often destroyed or removed from imported cars in order to use leaded petrol that is more widely available and cheaper than unleaded. The share of Soviet-made cars is still high but it is gradually decreasing.²⁵

²¹ <http://www.systra.com/SYSTRA-signs-two-contracts-with,683?lang=fr>

²² Mikheil Tushishvili. Sustainable Transportation in Tbilisi: current challenges and way forward. Workshop on Sustainable and Healthy Urban Transport. 29-30 October, 2008. Chisinau, Moldova.

²³ The Patrol Police. The Ministry of Internal Affairs.

²⁴ Noe Megrelshvili. Workshop on safe and healthy walking and cycling in urban areas 30 September-1 October 2001. Batumi, Georgia

²⁵ Mikheil Tushishvili. Sustainable Transportation in Tbilisi: current challenges and the way forward. Workshop on Sustainable and Healthy Urban Transport. 29-30 October 2008. Chisinau, Moldova.

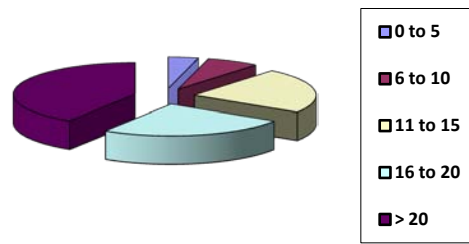

Figure 3: The Structure of Georgian Fleet of Vehicles by Age Groups in 2009.

Source: The Ministry of Environment Protection and Natural Resources of Georgia

According to an amendment (26.10.2008 # 5941) to “The Georgian Law on Traffic Safety”²⁶, the annual technical inspection of vehicles is voluntary rather than compulsory until January 1, 2011 (except for trucks and minibuses). This measure was intended to reduce corrupt inspection practices. However, only a small number of owners of vehicles underwent the inspection and paid for this service on a voluntary basis. According to the Traffic Police in Tbilisi, in 2004 only 3% (3,939 of the 128,988 registered units) of vehicles were subjected to a technical inspection.²⁷

Fuel Quality and Contribution to Air Pollution

The quality of fuel used by the local transport network is low and there is no efficient legal framework or institutional mechanism for fuel quality control. According to the amendment (30.12.2010 #421) to the Decree of Government on “Approval of Quality Standards for Gasoline”²⁸ the maximum level of lead in petrol should be 0.013 grams per liter until January 2012 and 0.005 grams per liter afterwards. According to the same Decree (30.12.2009 #421), national standards for petrol are defined as follows:

From January 1, 2010 to January 1, 2012	From January 1, 2012 to January 1, 2013	From January 1, 2013
<ul style="list-style-type: none"> • Lead content – 0.013 g/l; • Benzene – 5 %(v/v); • Aromatics – 45 %(v/v); • Sulphur content – 	<ul style="list-style-type: none"> • Lead content – 0.005 g/l; • Benzene – 3 %(v/v); • Aromatics – 42 %(v/v); • Sulphur content – 	<ul style="list-style-type: none"> • Lead content – 0.005 g/l; • Benzene – 3 %(v/v); • Aromatics – 42 %(v/v); • Sulphur content –

²⁶ The Georgian Law on Traffic Safety. 1999

²⁷ Challenges and possible solutions for sustainable urban transport in Tbilisi. Workshop on Sustainable Urban Transport and Land Use Planning. 18 -20 October 2006, Tbilisi, Georgia.

²⁸ Decree of Government on “Approval of Quality Standards for Gasoline” December 31, 2004 #124

500 mg/kg	200 mg/kg	150 mg/kg
-----------	-----------	-----------

The national standards for diesel are defined in the Decree of Government on the “Approval of Quality Standards for Diesel”²⁹. According to final amendments to the decree (30.12.2010, #422), diesel fuel used by the transport sector should meet the following standards:

From January 1, 2010 to January 1, 2012	From January 1, 2012 to January 1, 2013	From January 1, 2013
<ul style="list-style-type: none"> • Cetane No – 45; • Sulphur content – 350 mg/kg; • Density at 15°C – 845 kg/m³; • Polycyclic aromatic hydrocarbons – 11 % 	<ul style="list-style-type: none"> • Cetane No – 48; • Sulphur content – 300 mg/kg; • Density at 15°C – 845 kg/m³; • Polycyclic aromatic hydrocarbons – 11 % 	<ul style="list-style-type: none"> • Cetane No – 48; • Sulphur content – 200 mg/kg; • Density at 15°C – 845 kg/m³; • Polycyclic aromatic hydrocarbons – 11 %

As mentioned above, the majority of cars registered in the capital city are second-hand, averaging 20 years old, European cars that run better on higher-octane gas. Since the fuel imported in the country has a low octane level, often it is upgraded with lead additives to increase the fuel efficiency. Therefore, in practice lead concentrations are on average substantially higher than the statutory limits. There is no efficient legal framework, institutional mechanism, or research capacity (well-equipped laboratories and specialists), neither on national nor on local level that would monitor and control the quality of fuel and support meeting the standards listed above. Consequently, the high concentrations of air pollutants in fuel and their contribution to poor air quality remain to be problematic in the country and particularly, in Tbilisi. According to official data, throughout the country mobile sources contributed 38% of dust, 82% of SO₂, 89% of NO_x, 90% of the volatile organic compounds (VOC), and 95% of CO emissions in 2005³⁰. Unfortunately, there is no exact evaluation of the contribution of the transport sector to total CO₂ emissions. No public agencies have been designated to be responsible for the calculation and/or analysis of CO₂ emissions levels in the city. Negative consequences are not only environmental but health related too – in recent years cases of cancer and respiratory illnesses has dramatically increased in Georgia as a whole and particularly in Tbilisi.

²⁹ Decree of Government on “Approval of Quality Standards for Diesel” December 28, 2005 #238

³⁰ Challenges and possible solutions for sustainable urban transport in Tbilisi. Workshop on Sustainable Urban Transport and Land Use Planning. 18-20 October 2006, Tbilisi, Georgia.

There are a number of national laws, decrees, and orders regulating the transport sector and its environmental impact on the territory of Georgia: Georgian Law on Traffic (1995), Georgian Law on Traffic Safety (1999); Georgian Law on Ambient Air Protection (1999); Presidential Decree #302 on "Improvement of Environmental Safety of Road Transport" (2001); Presidential Decree #528 on "The Conception of Transport Policy of Georgia"(1997). However, the lack of coordination between responsible agencies, policies, goals and objectives for transport, city planning, environment and health protection at the national and local levels hinders an efficient enforcement of the existing legal mechanisms.

Transport Policy and Administration

The main agency responsible for the development, planning, monitoring and control of the transport sector of Tbilisi is **the Municipal Transport Department** at the Tbilisi City Hall. There is no special strategic document that would define long- and mid- term objectives within the transport sector. The only official document that briefly states the main priorities for the local transport sector development is the Strategic Plan for the Development of Tbilisi that was elaborated and adopted in 2009 by the city government as the main strategic document. The Budget of the City Hall is developed and adopted annually, presenting the main objectives and tasks identified under each sector, including transport. Since 2009, the element of mid-term planning was introduced in the process of budgeting – other than defining the concrete activities to be implemented in a single year the city budget envisages priority directions for the coming three years and evaluates relevant costs. It is worth mentioning that the lack of integrated, strategic and long-term planning within the transport sector hinders the efficient and systematic development of the Tbilisi transport network and infrastructure. ³¹

Behavior Patterns

Tbilisi has clearly become a car-oriented culture over the last decades. According to the results of a survey conducted among Tbilisi residents in 2008, the majority of respondents preferred to own a private car and avoid using public transport.³² Among the main reasons of the preference for owning private cars, convenience and time-saving were named as the top priorities.

³¹ With the support of The Asian Development Bank, the Tbilisi City Hall contacted the SYSTRA group to elaborate the Road Map for Georgian Sustainable Urban Transport Project. The Draft of the Road Map was finished in 2010.

³² Inga Grdzlishvili and Roger Sathre. Towards more effective urban transport policy: Understanding the travel behavior of Tbilisi residents. 2008

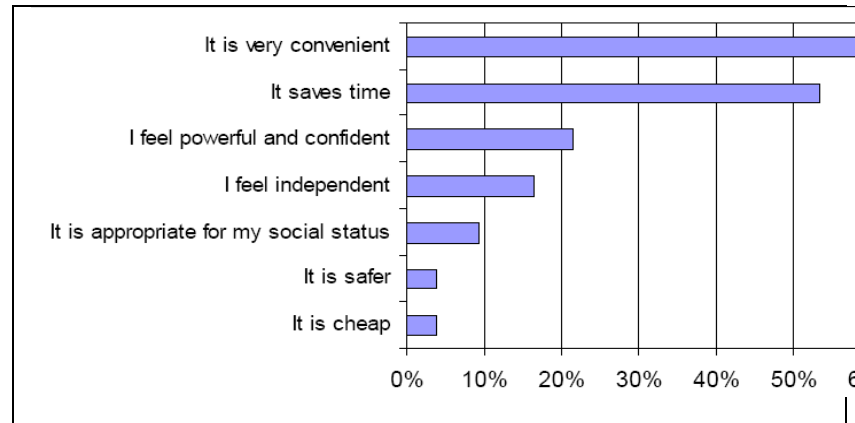

Figure 4. Responses by car drivers to the question “What do you like about driving your own car?”

The owners of private vehicles acknowledged that there were very few reasons why they would think about using alternative transport modes instead of driving their own cars. Their most possible reasons for using alternative transport were for increased traffic congestion (around 35%), inconvenience associated with parking (25%), and an increase in fuel prices (25%).

As for the passengers using public transport (PT) modes, they complained about the inconvenience and unattractiveness of public transport. Public transport users’ main concern is related to the price of transport fares. 77% of PT users were not satisfied with the price of transport.³³ The lack of comfort (including soft, clean seats, a pleasant temperature, air conditioning), frequent and direct links, short waiting times, fast journey and reliability were also named among the reasons why the use of public transport modes are less popular and desirable than owning private cars.

Interestingly enough, 43% of public transport users were aware of the environmental aspects of using public transport and preferred the latter for that reason. Therefore, promoting the environmental benefits of public transport can be among the strategic approaches while creating incentives for using public transport.

The survey also revealed that a combined mobility pattern is very rare. Those who own a car rarely use the public transport means even in the case of short-distance trips. Both, for private car owners and public transport users, the best option for short distance trips is by private car. Walking was named as the second option, followed by public transport. When asked about the benefits of walking, the owners of private cars stated a good opportunity to improve health conditions. According to the survey, 64% of public transport users use public transport every day, and 87% of public transport users do not own a car. Of the car driver group, 72% of car drivers drive their car every day. 94% of car drivers have used public transport at some time in

³³ In 2008, when the survey was conducted the public transport fee was 0.40 GEL per person. In 2010 the ticket price became 0.50 GEL.

their life; most of them use public transport only a few times per month or year. 6% report that they have never used public transport.

The results of the survey show that if certain measures (for example, reliable, affordable and convenient public transport; making driving a car less attractive through parking and fuel pricing) are implemented, the demand for private cars can be diminished and the number of the public transport users can be increased.

While discussing the patterns of travel behavior in Tbilisi, some recent changes and reforms should be mentioned as well since they considerably contribute to a generation of more responsible and effective driving habits. Among those positive changes are: increased penalties for violations of road safety rules (speeding, drunk driving, etc.); restrictions to use mobile phones while driving, and making the use of safety belts mandatory in the territory of the city.

1.2. Baseline Emissions Inventory for Transport Sector

Methodology

Long-range Energy Alternatives Planning System (LEAP) software has been used for the assessment of baseline (2009) CO₂ eq emissions from the Tbilisi City Transport Sector and for the projection of future trends by 2020. **LEAP** is a widely used software tool for energy policy analysis and climate change mitigation assessment developed at the Stockholm Environment Institute.

LEAP has been adopted by hundreds of organizations in more than 150 countries worldwide. Its users include government agencies, academics, non-governmental organizations, consulting companies, and energy utilities. It has been used at many different scales ranging from cities and states to national, regional and global applications.

LEAP is fast becoming the de facto standard for countries undertaking integrated resource planning and greenhouse gas mitigation assessments, especially in the developing world. The United Nations recently announced that more than 85 countries have chosen to use LEAP as part of their commitment to report to the U.N. Framework Convention on Climate Change (UNFCCC).

LEAP is not a model of a particular energy system, but rather a tool that can be used to create models of different energy systems, where each requires its own unique data structures. LEAP supports a wide range of different modeling methodologies. **This enables the user to create the structures which best fit his purposes – the user decides himself which sectors/ sub-sectors to include in the analysis and which to exclude.**

LEAP is designed around **the concept of long-term scenario analysis**. Scenarios are self-consistent storylines of how an energy system might evolve over time. Using LEAP, policy analysts can create and then evaluate alternative scenarios by comparing their energy requirements, their social costs and benefits, and their environmental impacts. The LEAP Scenario Manager can be used to describe individual policy measures, which can then be combined in different combinations and permutations into alternative integrated scenarios. This approach allows policy makers to assess the marginal impact of an individual policy as well as the interactions that occur when multiple policies and measures are combined.

Structure of the Tbilisi Transport Sector -Current Accounts

LEAP is a bottom-up, demand driven model. The structure of the energy sector in this model consists of three subsectors, these are:

- Energy Demand Sector
- Transformation and Distribution Sector
- Energy Resources Sector

As mentioned earlier, the flexibility of LEAP enables us to examine only the demand sector and transport sub-sector within it. The tools of representing these data in LEAP are quite flexible and simple. In the process of creating the model for any energy sector the first step is to elaborate the structure of the system where the initial information about the system is inputted. Afterwards, the possible evolution scenario and different mitigation scenarios are modeled and compared. The structure of the Tbilisi transport sector is based on the year of 2009 and has the following form:

Passenger Transport

All passenger transportation in Tbilisi is done either by private cars or by public transport:

- It was estimated that in 2009 the Tbilisi population traveled 7544 million passenger-km, 73% of which was done by private cars and 27% by public transport.
- Public transport is composed of busses (25.1%), mini-busses (50.3%) and a subway (24.6%).
- In 2009 the bus network served 56.9 million people. In total, the busses covered 58.4 million km.
- The mini-busses were estimated to travel 210 million km. The passenger turnover is approximately twice as much as for the bus network.
- The Tbilisi Subway reports 8.6 million km of travel and serves 94.9 million people annually.
- Private cars were estimated to have traveled about 58.4 million km. Surveys also estimate that cars have an average number of 1.85 occupants.
- The fleet of busses in 2009 was composed of 240 units of diesel busses with fuel consumption of 55 liters per 100 km, 150 units of diesel busses with fuel consumption of 38 liters per 100 km, and 544 units of diesel busses with fuel consumption of 24 liters per 100 km.
- The mini-busses operate on diesel and the average mini-bus has a fuel consumption of 12 liters per 100 km.
- The subway fleet consists of 170 units. In 2009 the total electricity consumption was equal to 62.95 thousand MWh/a. In addition to the existing metro fleet there are different service vehicles that run on diesel and gasoline.
- The 2009 the stock of cars was composed of vehicles running on gasoline (95%), diesel (4.4%), and natural gas (0.6%). The surveys have found that the average gasoline car has a fuel consumption of 12 liters per 100 km.

Commercial (Goods) Transport

- The total number of registered cargo vehicles in Tbilisi is 15,710. Their fuel consumption is estimated as 121 million liters of diesel. The available information is of the worst quality among all transport modes and will need further specification.

Municipal Fleet

- The Tbilisi municipality has 174 personal service cars, among them 164 operating on gasoline and 10 on diesel. The average fuel consumption of gasoline service cars is 14 liters per 100 km, and each travels about 33,600 km annually.
- The municipal fleet also includes 130 garbage service vehicles that operate on diesel. The total diesel consumption equals 438 thousand liters annually.

Other

- There are a small number of motorcycles registered in Tbilisi (around 1000), but because of their low share and unavailability of data about their mobility, they were neglected in this SEAP.
- Agricultural and other purpose vehicles (other than those included in the municipal fleet) registered in Tbilisi are not considered in this SEAP.

Reference Scenario Development

The current accounts represent a “snapshot” (initial status) of the city prior to implementing any mitigation measure. But it is very important to take into account the expected changes in the energy demand and consumption. Possible trends of development of the initial status in case there is no energy saving programmes implemented show a **reference scenario**. The reference scenario is usually considered to be a “**business as usual**” (BAU) scenario, because it shows how the initial status would change in the case that there is no municipal energy saving programmes implemented. For the Tbilisi Transport sector three main drivers were established that influence the energy demand in the Transport Sector. These drivers are:

1. **Population Growth** - Population growth directly influences the passenger turnover and commercial goods turnover. According to the World Health Organization, Georgia is among the countries with the lowest population growth in Europe. But as for Tbilisi, a small growth trend has been identified in recent years. **1.1% of population growth was estimated in Tbilisi and 0.5% population growth for the whole country for this reference scenario.**
2. **GDP Growth** - As research has shown, GDP growth directly influences the mobility of people (EUROSTAT). As income grows, people tend to move more. The GDP growth rates for Georgia were estimated according to the forecasts of the National Bank of Georgia in the following way:

	2012	2015	2020
GDP Growth	4%	5%	5%

Table 1: GDP Growth

The elasticity of mobility growth with respect to the GDP growth was estimated to be 1.3 (with a similarity to less developed Post-Soviet states in the EU, such as Lithuania and Latvia, where the rate of growth in the volume of inland passenger transport was between one quarter and one third faster than the rate of growth for GDP (Eurostat).

3. **GDP/Pop Growth** - Whenever population income grows, people tend to buy cars and prefer private cars to public transport. A recent drastic increase in the number of passenger cars is the main proof of this trend (233,187 registered cars in Tbilisi in 2009 versus 139,188 in 2004). Such trends are natural in countries that experience economic growth. For example, between 2000 and 2008 there was a significant increase in the use of passenger cars among many of the Member States that joined the EU in 2004 or 2007, in particular in Bulgaria (16%) and Poland (13%). Taking this into consideration, the elasticity of the growth of modal share of cars with respect to the GDP growth was estimated to be 0.2, which will end up with about 79.2% of modal share of cars in 2020. The growth of the cargo and municipal fleet is also linked to this demand driver with the same elasticity.

Results – Baseline Inventory

In 2009 the fuel consumption in the transport sector accounted for **5171.9** thousand megawatt-hours.

FINAL ENERGY CONSUMPTION (Thousand Megawatt-Hours) - 2009

	ELECTRICITY	Natural Gas	Diesel	Gasoline	Sum
Municipal Fleet			4.6	7.1	11.7
Public Transport	62.9	0	474.1	0.8	537.9
Private and Commercial Transport		88.2	1409.2	3124.9	4622.3
Subtotal Transport	62.9	88.2	1887.9	3132.8	5171.9

In 2009 the emissions from the transport sector accounted for **1323.7** tones of CO₂ eq.

CO2 EQUIVALENT EMISSIONS (Thousand Tons) - 2009

	ELECTRICITY	Natural Gas	Diesel	Gasoline	Sum
Municipal Fleet			1.2	1.8	3.0
Public Transport	25.2	0	125.6	0.2	150.9
Private and Commercial Transport		18.1	373.2	778.4	1169.8
Subtotal Transport	25.2	18.1	500.0	780.4	1323.7

Results – Baseline Scenario

According to the reference scenario, the energy consumption of the transport sector in the future significantly increases for all fuels. The demand will reach 9868 thousand MWh in 2020.

FINAL ENERGY CONSUMPTION (Thousand Megawatt-Hours) - 2020

	ELECTRICITY	Natural Gas	Diesel	Gasoline	Sum
Municipal Fleet			5.6	8.7	14.3
Public transport	99.6	0	750.4	1.3	851.3
Private and Commercial Transport		196.1	1860.5	6945.6	9002.2
Subtotal Transport	99.6	196.1	2616.5	6955.6	9867.8

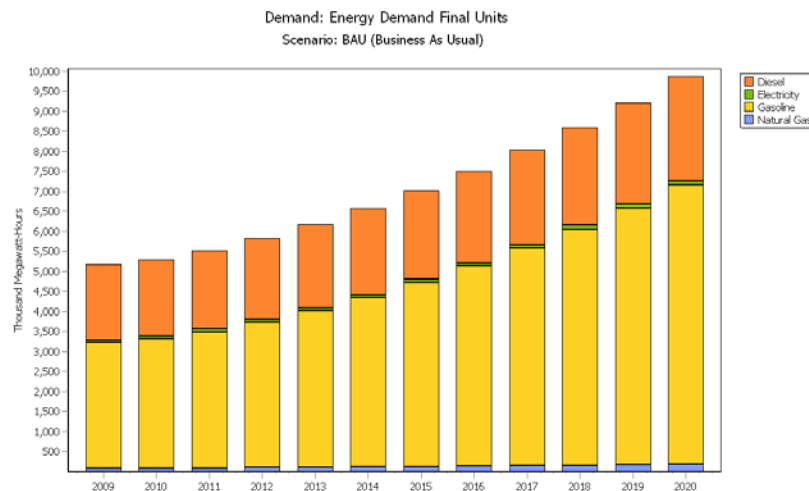

Figure 5. Energy demand trend (in MWh) in Tbilisi City transport sector for BAU scenario

The next table shows the emission inventory for 2020.

CO2 EQUIVALENT EMISSIONS (Thousand Tons)- 2020

	ELECTRICITY	Natural Gas	Diesel	Gasoline	Sum
Municipal Fleet			1.5	2.2	3.6
Public Transport	39.8	0	198.7	0.3	238.9
Private and Commercial		40.2	492.7	1730.2	2263.2

Transport					
Subtotal Transport	39.8	40.2	693.0	1732.7	2505.7

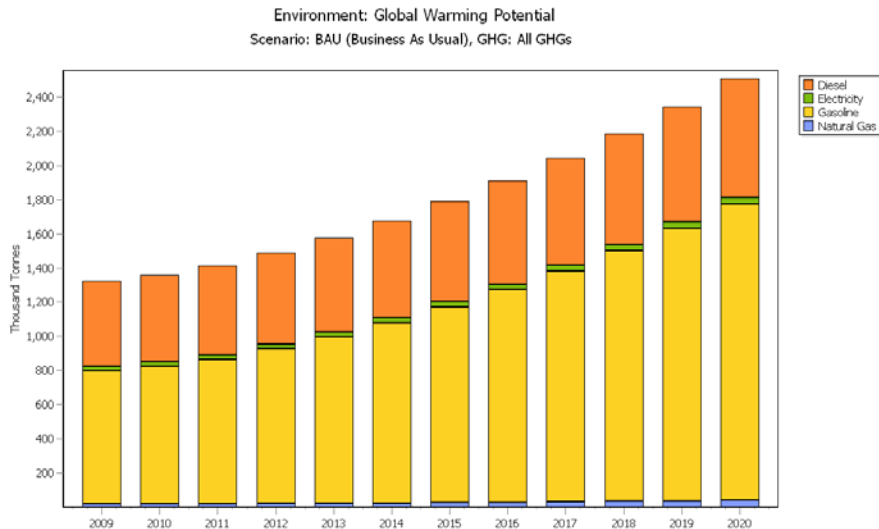

Figure 6. CO2eq emission from Tbilisi City transport sector for BAU scenario

The next figure shows the trends of emissions from the Tbilisi Transport energy sector according to the BAU scenario.

The measures considered in the SEAP will reduce CO2 emission from this sector by 394 thousand tones in CO2 eq by 2020, which is shown in figure below.

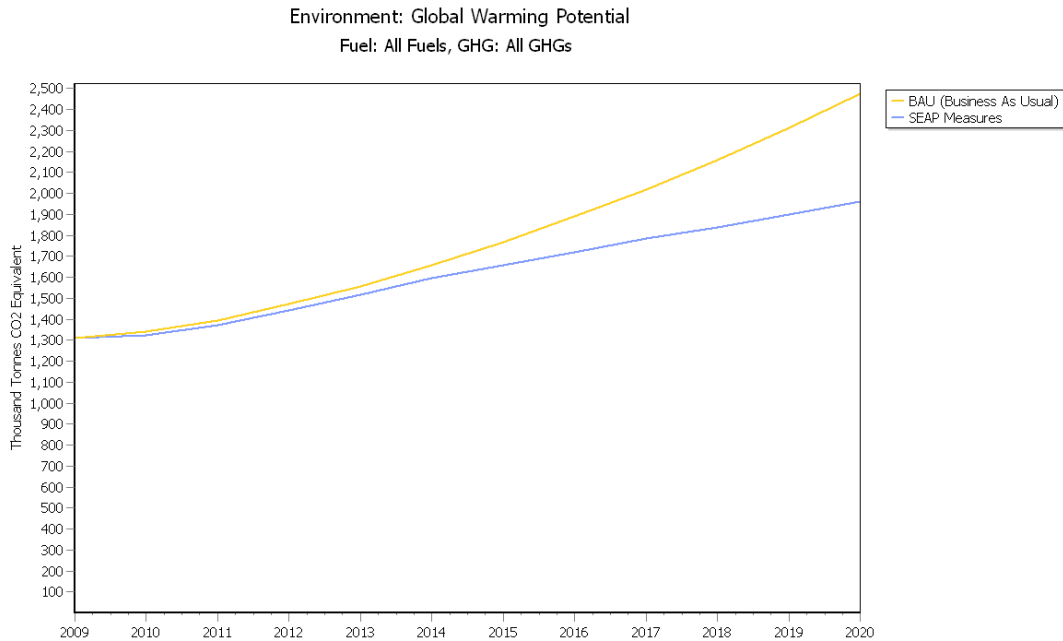

Figure 7. CO2eq emission trends from Tbilisi City transport sector for BAU and SEAP scenarios

1.3. Action Plan Table for Tbilisi Transport Sector

SECTORS & fields of action	KEY actions/measures per sector & field of action	Responsible Agency	Implementation Period [start & end time]	Estimated costs per action/measure	Expected energy saving per measure [MWh/a]	Expected renewable energy production per measure [MWh/a]	Expected CO2 reduction per measure [thsnd/t] in 2020	Energy saving target per sector [MWh] in 2020	Local renewable energy production target per sector [MWh] in 2020	CO2 reduction target per sector [t] in 2020
TRANSPORT:										513.0
<i>Municipal fleet</i>										
<i>Action M1:</i>	Renovation of Municipal Fleet	Economic Policy Agency, Tbilisi City Hall	2012-2013		3.96		0.99			
<i>Public transport</i>										
Action Y1:	Popularization Campaign for Public Transport (PT)	Economic Policy Agency, Tbilisi City Hall			137.69		30.54			
Sub-Action Y1.1	Information campaign (commercials, etc.)		2013-2020	to be defined						
Sub-Action Y1.2	Marketing		2013-2020							
Sub-Action Y1.3	PT web-page and transport guide development		2013							
Action Y2:	Improvement of PT service	Economic Policy Agency, Tbilisi City Hall			183.59		40.72			
Sub-Action Y2.1	The electronic display boards on 450 bus stops, showing times/schedules, etc		2012	1400000 GEL						
Sub-Action Y2.2	New Comfortable mini-busses		2010-2011							
Sub-Action Y2.3	Electronic display boards in mini-busses (2010-2011							
Sub-Action Y2.4	Improved top-up services		2010-2011							

Sub-Action Y2.5	Technical Inspection of mini-busses		2010-2011									
Sub-Action Y2.6	Improved safety measures in minibuses		2010-2011									
Sub-Action Y2.7	Better pricing schemes		2010-2011									
Sub-Action Y2.8	Improvement and optimization of routes		2011-2020									
Sub-Action Y2.9	Dedicated Bus lanes		2015-2017		to be defined by feasibility study							
Action Y3:	Alternative PT service	Economic Policy Agency, Tbilisi City Hall							306.05			69.18
Sub-Action Y3.1	Optimization of bus fleet		2010		---							
Sub-Action Y3.2	Extension of Subway to University Station		2013-14		54000000GEL							
Sub-Action Y3.3	Development of Tram Network		2014-15		to be defined by feasibility study							
<i>Private and commercial transport</i>												
Action R1.	Private cars discouraging actions	Economic Policy Agency, Tbilisi City Hall							271.75			60.50
Sub-Action R1.1	Environmental islands		2017-2020		to be defined by feasibility study							
Sub-Action R1.2	Pricing		2017-2020									
Sub-Action R1.3	Parking management		2017-2020									
Action R2	Encouragement of low emission cars	Economic Policy Agency, Tbilisi City Hall	2015-2020		to be defined				669.52			179.40
<i>Other - please specify:</i>												

Sustainable Energy Action Plan – City of Tbilisi

Action G1:	The Street Light Management Centre	Economic Policy Agency, Tbilisi City Hall				491.06		123.85			
G1.1	Gamsaxurdia st Green Wave		2010		388280 GEL						
G1.2	Budapeshti-Vazisubani str. Green Wave		2010		9661 GEL						
G1.3	Green Wave by Isani station		2010		330650 GEL						
G1.4	Green Wave at Tsereteli ave		2012		1203125 GEL						
G1.5	Green Wave at Kazbegi ave		2012		687500 GEL						
G1.6	Green Wave at Guramishvili and Dadiani ave		2013		2578125 GEL						
G1.7	Full run Street light management centre		2020		2750000GEL						
Action G2:	Improved Road Infrastructure	Economic Policy Agency, Tbilisi City Hall				30.98		7.81			
G2.1	Intensification str		2010		2673000 GEL						
G2.2	New street from Heroes Square		2010		91826000 GEL						
G2.3	Gelovani-Agmashenebeli Tunnel		2011		8486000 GEL						
G2.4	Tunnel at Gorgasali str		2012		8486000 GEL						
G2.5	New Street connecting Sheshelidze and Gobronidze str		2011		1000000GEL						
G2.6	New bridge connecting Poti and Dadiani str		2015		54000000GEL						
					TOTAL:	2094.6		513.0			513.0

1.4. Description of Actions

Actions G1 - Traffic Lights Management Centre

The establishment of a traffic light management center is planned for Tbilisi, which will gradually include 160 traffic light objects. The latter will support the formation of so-called “green waves” on corresponding territories, which will decrease the moving time of vehicles, the number of stops at traffic lights, and as a result eventual fuel consumption. Traffic lights will be added to the management center in the following order:

G1.1 - Pekini Avenue Green Wave: On average, 2400 vehicles run on Pekini Avenue in one direction and have to go through 6 traffic light points. Of 2400 vehicles, 1600 had to stop at four traffic light points. After the Green Wave system was introduced and a new road on Heroes Square was constructed, the number of cars running on Pekini Avenue was decreased to 2100 vehicles per hour (300 vehicles now use the new road). Out of 2100 vehicles, 800 cars have to stop at only two out of six points.

G1.2 - Budapeshti-Vazisubani Streets Green Wave: On average, 2300 vehicles run in one direction through four traffic light points. 1800 vehicles had to stop at three points. After the Green Wave system was introduced, 1100 vehicles out of 2300 have to stop only at two points.

G1.3 - Green Wave by Isani Metro Station: On average, 2100 vehicles run through three traffic light points in one direction. 1500 vehicles have to stop at two points. Within the Green Wave system, 900 vehicles out of 2100 have to stop at one point

G1.4 - Green Wave at Tsereteli Avenue: On average, 1800 vehicles run per hour. 1500 vehicles have to stop at 5 points out of 7. When the Green Wave system is introduced, 1500 vehicles will stop at 2 points in one direction.

G1.5 - Green Wave at Kazbegi Avenue: On average, 2300 vehicles run per hour. 2000 vehicles have to stop at four out of six points. When the Green Wave system is introduced, 2000 vehicles will stop at two points.

G1.6 - Green Wave at Kazbegi Avenue: On average, 2300 vehicles run per hour. 2000 vehicles have to stop at four out of six points. When the Green Wave system is introduced, 2000 vehicles will stop at two points.

G1.7 – Full Run Intelligent Traffic Lights Management Centre: Every following year 15-20 traffic light objects will be added to the management center. By 2020 a total of 150-160 objects will be included in the management center.

Actions G2 - Improved Road Infrastructure

G2.1 - Intensification Road: An Intensification Road will offer a 2 km shorter route to travel from the Agmashenebeli Monument in the direction of Saburtalo district.

G2.2 - New Road from Heroes' Square: In one hour 1000 vehicles run in one direction on the new road. Before the construction of the road, cars had to travel 4.0 km through Kostava Street, Pekini and Vaja-Pshavela Avenues and to stop at 9 traffic light spots to reach the Delisi Metro station from Heroes' Square. To reach Bagebi neighborhood, vehicles had to travel 4 km from Heroes' Square through Varaziskhevi and Chavchavadze Avenue and stop at 8 traffic light points. The new road is a 200-400 meter longer route; however vehicles do not have to stop at any traffic lights.

G2.3 - Gelovani-Agmashenebeli Tunnel: Construction of the Gelovani-Agmashenebeli Tunnel has begun. As a result, 3600 vehicles will travel without stopping at traffic lights.

G2.4 - Tunnel at Gorgasali Street: After the construction of the Tunnel, 2000 vehicles will travel without stopping at traffic lights.

G2.5 - New Street connecting Sheshelidze and Gobronidze Street: The construction of a new street connecting Sheshelidze and Gobronidze streets will be launched and completed.

G2.6 - New Bridge Connecting Poti and Dadiani Streets: The construction of a new Vakhushti bridge connecting Poti and Dadiani streets will be launched and completed.

Actions Y1- Popularization Campaign for Public Transport

Y1.1- Information Campaign: Public awareness will be raised regarding the benefits of public transportation – it should be promoted as a reliable, fast, comfortable, safe, cheap and accessible means of transportation. Citizens will be provided with accurate information about the advantages of public transport in comparison to other transportation modes.

Y1.2 – Marketing: Marketing and branding activities of the Public Transport System will be conducted to make the public transport service more attractive – working with citizens and different focus groups, branding public transport modes, marking stations and vehicles etc. The marketing strategy will be used as a systemic tool, enabling transport managers to identify a market's expectations, to define the level of quality offered depending on the corporate strategies and to measure the customers' perception and to process readjustment. At an operational level, marketing tools have been proven to increase revenue, improve quality, and

reduce costs. The use of marketing will enable a permanent improvement in all customer-relations activities like sales, advertising, branding, network design, product specification, complaint management, and customer service

Y1.3 - Public Transport Web Page and Guide: A special web page will be developed to provide the public with detailed information about the routes, lines, timetables, and fees of all modes of public transport. Information brochures will be prepared and distributed. The brochures will serve as a guide and map while using the public transport, especially for tourists. They will be distributed in airport, hotels, railway stations, tourist agencies, food places, souvenir shops etc.

Actions such as an information campaign for raising awareness among citizens and stakeholders, marketing, etc. do not affect energy consumptions and CO₂ emissions directly, but act as a powerful tool to amplify the effects of other actions. It was estimated that these actions would increase the modal share of public transport by 3% by 2020.

Actions Y2 - Improvement of Public Transport Service³⁴

Y2.1 - Electronic Display Boards on 450 Bus Stops: Electronic display boards will be installed at 450 bus stops. Commuters will be informed about the arrival time of concrete modes and routes of public transport. It will increase the convenience of travelling by public transport modes. The approximate cost of the project is 1,400,000 GEL.

Y2.2 - New Comfortable Minibuses: In the summer of 2011 new Ford Transit minibuses (with a Euro 4 engine) will be introduced in the capital city. The minibus service will improve considerably: which will increase the attractiveness of public transport and make it popular.

Y2.3 - Electric Display Boards in Minibuses: The minibus vehicles will be provided with electric boards displaying the routes. The boards will be visible during the nighttime and daytime.

Y2.4 - Better Top-Up Services: Top-up machines will be installed at bus stops, so that commuters are able to top-up their plastic travel cards.

Y2.5 - Technical Inspection of Minibuses: Minibus vehicles will go through technical inspection before starting the service provision on a daily basis.

Y2.6 - Increased Safety: Standing while travelling will be prohibited in mini-buses to ensure safety of passengers; drivers will go through alcohol and drug tests on a daily basis.

³⁴ In a short-term strategy the feasibility study will be conducted to evaluate the effectiveness of actions marked with an asterisk.

Y2.7 - Improved Ticketing System: A common payment system for bus, minibus, and metro will be introduced. Special discount offers (similar to ones for buses and the metro system) will be elaborated and offered to socially vulnerable people.

Y2.8 - Improvement and Optimization of Routes: The bus fleet will be reduced from 125 bus lines to 92, automatically resulting in a decrease of buses running in the city.

Y2.9 - Dedicated Bus lanes*: Dedicated bus lanes will allow buses to operate separately, without interference from other modes of traffic. In the first stage, a feasibility study will be conducted. Pilot projects will be implemented in order to evaluate the effect of total passenger turnover.

These measures are aimed at making public transport more comfortable and easier to use. They don't directly affect the emissions, but act as a powerful tool to amplify the effects of actions, which will be introduced at the late stage (like private car restricting actions). It was estimated that these actions will increase the modal share of public transport by 4% by 2020.

Actions Y3 - Alternative PT Service

Y3.1 - Optimization of the Bus Fleet* - Big and fuel intensive buses will be removed from the fleet.

Y3.2 - Extension of Subway to the University Station: There will be an extension of line 2 to University, at the end of Saburtalo district; the tunnel to University station has already been built. The completion of the metro extension (1.5 km long), including additional civil works, implementation of systems and the creation of a station is included in this investment program. This extension is expected to add 4.4 million passengers per year to the metro network. It can be noted that additional vehicles are not required for operations. The project will be partially funded by the Tbilisi municipality and partially by the Asian Development Fund (ADP).

Y3.3- Tram Line: In the nearest future alternative public transport modes, such as tram lines will be introduced in Tbilisi. A modern electric tram system has following advantages in comparison to other transport modes:

- Safety (proved by many developed countries)
- Minimal pollution and CO₂ emissions
- Less noise in comparison to other transport modes (buses, etc.)
- Comfortable for elderly as well as disabled people
- Large capacity – 3000-15000 passengers per hour in one direction
- Speed – 25-30 km/hr on average
- Less energy consumption

- Attractive for tourists

The consulting company SYSTRA will conduct a feasibility study and develop the design of the Tbilisi tram network. The feasibility study will be ready at the beginning of 2010 and will highlight the exact cost of the project.

In this SEAP we are considering a 16 km tram line from Delisi to Samgori, a 23 km line from Didi Digomi to Samgori, a 15 km Cahvchavadze–Rustaveli line. Buses and minibuses will be substituted with a modern electric tram with low CO₂ emissions. The research also shows that private car users are more prompt to change for transport like tram than other modes, like buses. According to statistics the tram takes 30% of its users from private car users. It is envisaged that the project will be funded by a loan from the Asian Development Fund (ADP).

Actions R1- Private Cars Discouraging Actions

R1.1 - Environmental Islands: So-called “environmental islands” are the result of a combination of measures designed to: prohibit or penalize private vehicle traffic in the areas concerned, reduce the amount of roads available for private traffic and the average speed of vehicles, guarantee optimum road safety, favor the flow of public transport and the mobility of cyclists and pedestrians.

R1.2 – Pricing: By making car drivers pay a fee for driving in the city (especially, the city centre), drivers can be charged some of the social costs of urban driving, thus also making cars a less attractive option. Experience from local authorities that implemented congestion charges, shows that they can reduce car traffic considerably and boost the use of other transport modes. Pricing can be an effective instrument to reduce congestion and increase accessibility for public transport.

R1.3 - Parking Management: Parking management is a powerful tool for local authorities to manage car use. They have several tools to manage parking like pricing, time restrictions, and controlling the number of available parking spaces. Parking time restrictions for non-residents, (limiting them for to two hours, for example), is a proven tool to reduce commuting by car without affecting accessibility to urban shops.

Thorough feasibility studies must be undertaken for these actions before their implementation. Because it is hard to determine their effect without these studies, it was estimated that these actions would decrease the modal share of private transport by 5% by 2020.

R1.4 - Encouragement of Low Emission Cars: It is foreseen that from 2015 technical inspection of cars will become obligatory: This will help to introduce different encouragement measures for new eco-friendly vehicles replacing the highly polluting gasoline and diesel vehicles and implementation of other measures designed to reduce environmental impact, like low or no parking tariffs

for low emission vehicles, lower tariffs at technical inspection, lower tariffs for taxi drivers if their car has lower emission, etc.

M1. Municipal Fleet Renovation: 80% of municipal personal service cars will be substituted with smaller 1.1 motor capacity cars.

2. Building Sector

2.1. Current Situation and Future Trends

In recent years some positive changes have taken place in Georgia with regard to energy saving issues in the building sector. The Tbilisi Municipality has implemented several programs, including a partnership program that targets energy efficiency issues in buildings. The framework agreement on “Municipal Energy Efficiency Planning” (MEEP) with Energy Saving International (ENSI), a Norwegian energy efficiency and energy business development consulting company, covered energy efficiency aspects in buildings, the training of municipal key personnel, as well as the development of a municipal building database with the purpose of identification and reduction of energy consumption in the municipality-owned buildings and the planning of future energy saving actions.

USAID has implemented over 30 pilot projects targeting energy efficiency as well as supported a research assessment on energy efficiency and renewable energy potential in Georgia. The residential construction sector of Tbilisi has also been assessed from an energy efficiency perspective. USAID-Winrock launched the NATELI project, aimed at energy efficiency interventions in public and hospital buildings. The project framework has also foreseen cooperation with the municipality in targeting common properties of residential buildings.

Within the INOGATE-SEMISE project preparatory assistance work for SEAP has been done to Tbilisi City Hall.³⁵ According to this assessment the greatest energy saving potential can be found in buildings and the transportation sector.

The Energy Efficient Strategy for buildings deals with causes and implications of climate change. It aims to reduce energy needs and shift to a culture of conservation, empowering responsible administrative parties and residents to make new choices for new savings. This strategy plans in future to reduce energy bills and contribute to economic development of the city in a sustainable way by implementing energy efficiency measures in buildings and reducing CO₂ emissions.

An energy efficiency approach for the building sector differentiates strategies with respect to existing and newly constructed buildings. It is based on recognizing and

³⁵ INOGATE: Energy Cooperation between the EU, The Littoral States of the Black and Caspian Seas and their Neighboring Countries. SEMISE: Support to Energy Market Integration and Sustainable Energy in NIS.

sharing a sustainable development vision and commitment to reduce energy consumption. New buildings can be initially designed and afterwards constructed with enhanced energy efficiency in the building's structure. In such a case, energy savings can constitute about 40-50% of the heating system's energy consumption. Existing buildings' thermal performance structure can be enhanced through refurbishment, the use of efficient technologies, and changes in consumer behavior that will contribute to an emissions reduction of 20% by 2020.

The current legislative framework in Georgia includes laws that can be considered by the municipality as policy guidance that reflects climate mitigation issues:

The resolution of the Georgian Parliament 25/37 on December 27th, 2005, "Main Directions of State Policy in Georgian Power Sector" and the Parliament of Georgia approved the document prepared in the Ministry of Energy on 7 June of 2006 and determined main directions of energy policy.

Order of the Ministry of Environment Protection and Natural Resources of Georgia № 704 on 20 October, 2008, "Concerning the rule of inventory of air pollution from stationary sources"

- Law on Environmental Protection
- Law on Ambient Air Protection

In Tbilisi, the vast majority of building energy waste is because of poor design, inadequate technology, and inappropriate behavior. Unfortunately Georgia has not yet adopted construction codes that reflect energy efficiency in buildings. It is understandable that with the absence of a legislative framework the SEAP strategy can't reflect measures that are out of municipal jurisdiction. The municipality policy can consider the issue of energy efficiency in new buildings as a "soft tool" that should be limited only to information campaign. Thus the strategy should concentrate on existing buildings, underlining specific, realistic, and achievable cost effective measures that are considered within city peculiarities as priorities for the municipality to target social and financial aspects that can be implemented by 2020 to reach the declared emission reduction.

2.1.1. Energy Consumption Analysis of Buildings

Analysis of the Thermal Properties of Buildings

In Tbilisi the municipal building stock constitutes 196 facilities with a total floor area of about 350,000 m².

Municipal buildings in Tbilisi can be divided into three categories:

- Category 1 - 158 educational and cultural facilities
- Category 2 - 17 sports facilities
- Category 3 - 21 health care facilities³⁶

All municipal buildings were built during the Soviet era; part of which have been repaired but without considering energy efficiency upgrading. The only measure that has been implemented during repairs in part of the municipal buildings and can be considered a contribution to energy efficiency for the structure of buildings to date is the installation of double-glazed windows.

The residential sector of Tbilisi accounts for an estimated 37 million square meters. The energy consumption of the existing building stock has been analyzed from a thermal properties perspective including: building compactness requirements (geometric form) that aims at an assessment of the ratio of the envelope's surface area to its volume, age profile, construction materials as well as window glazing common practices.

Tbilisi is an old city with a huge central historical area. Part of this was formally designated as the “Old Tbilisi District”. This part is mostly consists of pre-1917 buildings, which may account for about 10-12% of all the residential building stock of Tbilisi (Picture 5).



Picture 5: Old building in the central historical part of Tbilisi

These buildings are mostly up to three stories high, made of brick (often of local variety, which are square and flat). Windows are single-glazed with wooden

³⁶ Several kindergartens aren't currently functioning because IDPs occupy them.

frames, often deteriorated beyond repair, if residents have not replaced them with modern metal-plastic ones, which is rather unusual.

An examination of the old city residential building stock from the standpoint of the buildings' compactness shows that they have been mostly well designed and do not have a high ratio of envelope surface area to its volume, thus from this perspective they aren't characterized by excessive heat losses.

Construction practice in that time was characterized by exterior walls with a thickness that in general can be summarized as follows: $\delta = 0.7 \div 1.0$ m. This means that the above buildings are defined as high thermal capacity buildings with low heat losses from the exterior walls. The estimated energy efficiency level of these buildings is much higher than buildings that have been constructed during the Soviet era, when legislative requirements towards energy efficiency weren't reflected in thermal engineering codes. The energy efficiency level of these walls can be roughly estimated by thermal resistance values as: $R = 1.0 - 1.5 \text{ m}^2 \text{ C/W}$.

An expert's assessment shows that these thermal resistance values are 2-3 times higher than the Soviet period construction practices, despite the fact that thermal engineering parameters of exterior walls' thermal properties decrease with the age of the building. It is important to emphasize that the structure of these buildings is rather deteriorated and some are seriously damaged, thus a full-cycle assessment of the abovementioned old Tbilisi residential building stock is needed to define which of these buildings should be demolished or renovated. Roofs of old-type residential buildings were designed with attics, so a decision to insulate roofs in each case should be undertaken during the rehabilitation of buildings.

For the most part about 65% of the remaining residential building infrastructure, known as post-60s multi-flat buildings, was built during the Soviet period. At the beginning of the 1960s, the design style was a 5-floor multi-flat building, known as the "Khrushchev Era" building. Thermal engineering and construction requirements of that time reflected governmental policy, which was aimed at satisfying the housing needs of the population but built to meet minimum housing standards. The designed lifetime of the "Khrushchev Era" buildings was 25 years.



Picture 6: Soviet era multi-apartment building block

Many of them were built five decades ago. The most common design types of that time were: N 1-319C, N 1-450C, N 1-464AC. Each series was designed with different construction materials to withstand magnitude 7 earthquakes. The first of these housing units were usually built from bricks, which were later replaced by large construction blocks and panels. The following series were characterized by a higher number of floors (8) but had the same typical apartment layout.

Thermal property characteristics of buildings designed in that period were low due to the minimum sanitary-hygienic comfort criteria requirements. Residential buildings constructed in that time were specified by mandatory thermal resistance values for walls that didn't exceed: $R=0.575 \text{ m}^{20}\text{C}/\text{W}$ according to construction thermal engineering codes. It should be noted that codes were slightly changing with time, but the above mandatory value was the highest in the former construction thermal engineering codes' practices.

The mass construction called for a new approach. Use of one-layer concrete walls became widespread. The thickness of walls was defined based on the technology and structural requirements rather than on thermal engineering ones. The technology and structural requirements benchmark approach in the same climatic conditions required the following thicknesses: for block walls - 40cm, for panel walls - 30cm, and for frame panel buildings - 25cm. Windows were almost always single-glazed.

This means that a large amount of the post-60s multi-flat buildings in Tbilisi have been designed with structural characteristics based on the excess stationary supply of heat in winter covered by district heating systems with a central boiler that had to operate 24 hours a day.

Roofs in these buildings are mostly flat, insulation and waterproof layers were considered initially in the design and implemented in the construction phase, but

with time these materials deteriorated due to their common lifetime (maximum of 30 years) for insulation construction materials that were produced in the USSR.

The Tbilisi city residential sector also incorporates a private housing component of one/two family houses. These houses were built during the Soviet era and mostly stick to common construction practices that were used at that time. They were usually built from brick (earlier units) or cement blocks (later units). The thermal resistance values of walls in small private houses in general can be benchmarked as the mandatory thermal resistance values ($R=0.575 \text{ m}^2\text{C/W}$). This shows that the thermal properties in this type of housing also need an excess stationary supply of heat.

With independence, a new era started in the residential construction sector in Georgia, one of the promising sectors from an economic development standpoint in Tbilisi. Only two considerations as judgment criteria have been taken into account regarding the design of new buildings:

- static stability of the new buildings
- hydrogeology assessment

Few details can be added to this picture: developers started to use only two types of former Soviet codes, according to the judgment criteria given above. It was understood that other former Soviet codes were not obligatory to use, thus in many cases they have been ignored, including the construction thermal engineering codes that benchmarked mandatory thermal resistance values. The elaboration of new Georgian codes in the field of construction thermal engineering has been postponed many times.

In the construction sector, the frame construction method has been adopted as one that matched static stability criterion, but this construction process is still different from the Soviet era frame construction practices. During the Soviet period, the frame construction elements were covered by external panels, but in today's construction practices wall blocks of present buildings are located in-between frame elements, which creates thermal bridges.

Double-glazed windows are widely used in new buildings, composed of frames produced in Georgia and imported glass, but it isn't obligatory to certify the final completed product, thus thermal resistance values of double-glazed windows may vary to some extent. The assessment of new buildings showed that in general they aren't consuming less energy despite the fact that they all have double glazed

windows. This is because of the thermal resistance values of the building, exterior properties are low, and in the best cases stick to the former mandatory values.

As buildings have a relatively long life, major refurbishments should necessarily take place during their lifespan – which can be around every 30 to 40 years for residential buildings. This should take place because major parts of the buildings and installations will be wear-out and have to be replaced, because of lifestyles and demands for comfort that are constantly changing in modern society. Replacements and smaller refurbishments might even occur more often. These refurbishments and/or changes in equipment provide a compelling opportunity to improve a building's efficiency. Energy savings can often be obtained at lower costs when other constructions are taking place. In some cases additional improvements require only small or no additional funding if the basic construction requires work or the equipment is replaced, in other cases it can save on construction costs.

The requirement for energy efficiency by refurbishment is therefore an important issue that should be highlighted in building codes.

The assessment of the existing residential building stock provides grounds for conclusions that can be summarized as follows:

- the existing residential building stock has a great energy saving potential
- it is important to conduct energy audits for the identification of cost saving measures
- energy efficiency measures in buildings themselves can be divided into two categories:
 - *addressing thermal property issues*
 - *addressing end-use technology application issues*
- in gaining good energy saving results it isn't suggested to use only one cost effective measure like the end-use technology application project
- projects that incorporate insulation of the exterior building components have a greater energy saving potential but are characterized with high investment costs
- energy efficiency projects should reflect an overall energy efficiency strategy of the city in the relevant sector
- public awareness is needed for the involvement of residents into an energy savings campaign

Energy Consumption in the Tbilisi Buildings Sector

Buildings in Tbilisi consume about 40% of all energy. As was already mentioned, the residential sector of Tbilisi accounts for 37 million square meters and is represented by three subsectors: primarily multi-flat buildings (60-65%) that have been built during the Soviet era, individual housing (constituting about 20-25%), and mixed-type flats (10-20%).

The heating season in Tbilisi constitutes 146 days. Central heating systems with boiler houses were dismantled after the collapse of the Soviet Union, because they were designed to work as parts of a centralized hydronic heating system and couldn't be retrofitted to serve the needs of individual houses/flats after the system collapsed at the beginning of the 1990s. These systems can't be restored in principal because major parts of them are simply missing (households have already dismantled and scrapped piping and radiators).

The population of Tbilisi faces problems with heating in winter. There is no government-sponsored solution to this problem, thus each household has to solve it within its own financial and organizational means.

It is known that the exterior properties of buildings determine the load of the heating system, which is true for Tbilisi and Georgia as a whole. The vast number of buildings designed during the Soviet period is characterized by high heat loss due to poor thermal properties. The majority of a building's energy is wasted because of poor design, inadequate technology, and inappropriate behavior.

The priorities of that time didn't take into account energy performance concerns; energy was cheap and thermal property design solutions were shifted to satisfy only minimum energy performance indicators.

As was mentioned in the analysis of the exterior properties of the buildings (section 3.1), they were designed to comply with heating system solutions that had to cover huge heat losses to reach comfortable indoor conditions since energy at that time was cheap and could simply be wasted. It should be noted that over the years the thermal properties of these buildings have worsened. This means that the design parameters of the initial mandatory thermal performance indicators have become even lower now, and a huge amount of energy defines these buildings' baseline energy consumption. Thus a considerable part of the population in Tbilisi lives below comfortable conditions in winter because they simply can't cover energy bills.

During the heating season the population of Tbilisi shifts mostly to a natural gas energy carrier and in a majority of cases uses various kinds of individual gas heaters, as well as electric heaters (and much to smaller extent central hydronic heating systems with boilers, mostly in apartment systems) and air conditioners. Electric and gas heaters very often don't cover the baseline energy consumption for heating, but bills indicate a high consumption.

Energy produced from renewable energy sources is represented by a geothermal hot water supply in part of the Saburtalo district in Tbilisi. Currently geothermal water (mostly for domestic hot water supply purposes) is supplied to 78 buildings. The water supply isn't constant, but instead rather sporadic. There is no metering, so the charge per household constitutes 3 GEL per month. A market analysis has been carried out in order to evaluate the economic feasibility of installing a new geothermal hot water supply system in the Saburtalo pilot district.

It should be noted that technical solutions and modern technologies should be applied to reach a significant improvement in the utilization of geothermal water potential, because nowadays the distribution network pipelines aren't insulated and geothermal water received from the production well isn't returning back through a reinjection well. Hot water is distributed for a limited number of hours; very often without any schedule. The amount of water as well as its pressure in the system, especially in winter, is low. A pilot project should be launched for the identification of technical solutions aimed at improving the utilization of thermal water potential.

Energy Consumption Data

Energy consumption data for Tbilisi is presented below.

Year	Electricity Consumption of Tbilisi, mln kWh				Electricity Transit for Tbilisi subway, mln kWh
	Residential	Commercial	Budget Funded	Total	
2000	776.73	316.01	85.19	1,177.93	73.41
2001	595.82	391.44	100.90	1,088.17	75.16
2002	650.82	440.72	123.84	1,215.37	76.02
2003	623.34	449.99	124.92	1,198.24	80.49

Sustainable Energy Action Plan – City of Tbilisi

2004	614.96	403.38	212.74	1,231.07	72.00
2005	663.98	438.72	221.36	1,324.06	63.79
2006	727.80	477.90	188.80	1,394.50	64.41
2007	716.82	532.37	153.60	1,402.80	62.72
2008	781.31	576.54	158.43	1,516.28	63.10
2009	798.03	579.40	166.59	1,544.02	62.06

Table 3.1 Electricity Consumption Data

The population of Tbilisi is about 1,170,000. A population breakdown by district is given in Table 3.2, below.

Districts	Population
Vake	130,000
Saburtalo	130,000
Mtatsminda	60,000
Krtsanisi	50,000
Isani	130,000
Samgori	170,000
Didube	90,000
Chughureti	70,000
Gldani	180,000
Nadzaladevi	160,000
Total	1,170,000

Table 3.2 Tbilisi population by district

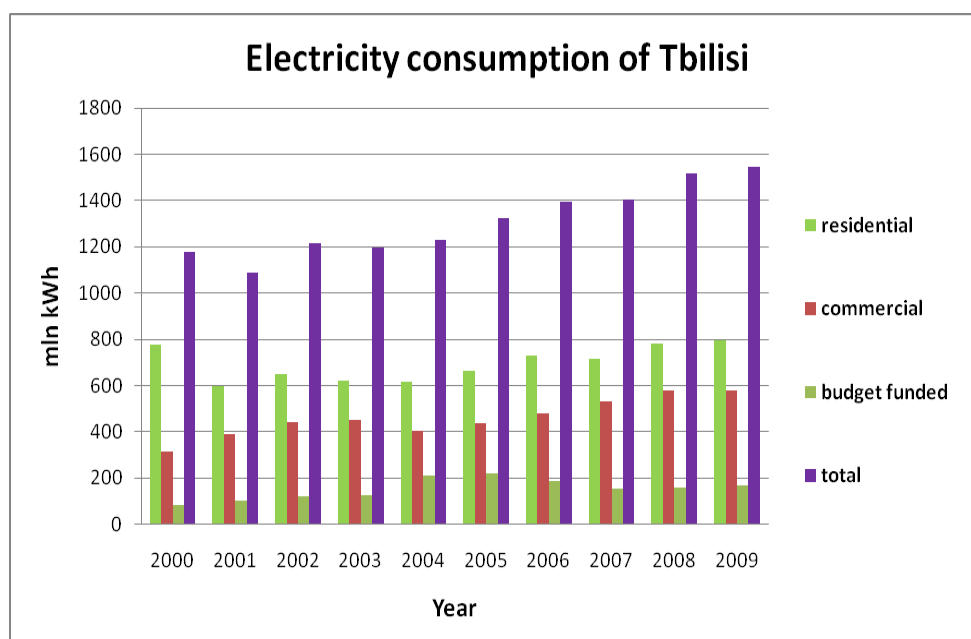

Figure 3.3 Electricity consumption diagram of buildings sector in Tbilisi

Year	Natural Gas Consumption of Tbilisi, cubic meter			Number of consumers in the residential sector of Tbilisi
	Total	Residential sector	Other	
2001	55,716,935	39,514,988	16,201,947	153,602
2002	64,198,673	47,202,264	16,996,409	197,551
2003	87,175,863	66,346,740	20,829,123	234,465
2004	125,518,816	96,676,967	28,841,849	258,700
2005	162,021,975	117,577,961	44,444,014	278,139
2006	220,263,752	167,334,114	52,929,638	296,978
2007	269,997,725	207,793,483	62,204,242	300,205
2008	269,637,230	201,876,648	67,760,582	304,852
2009	273,796,902	203,571,665	70,225,237	311,177

Table 3.3 Natural gas consumption of Tbilisi in cubic meters

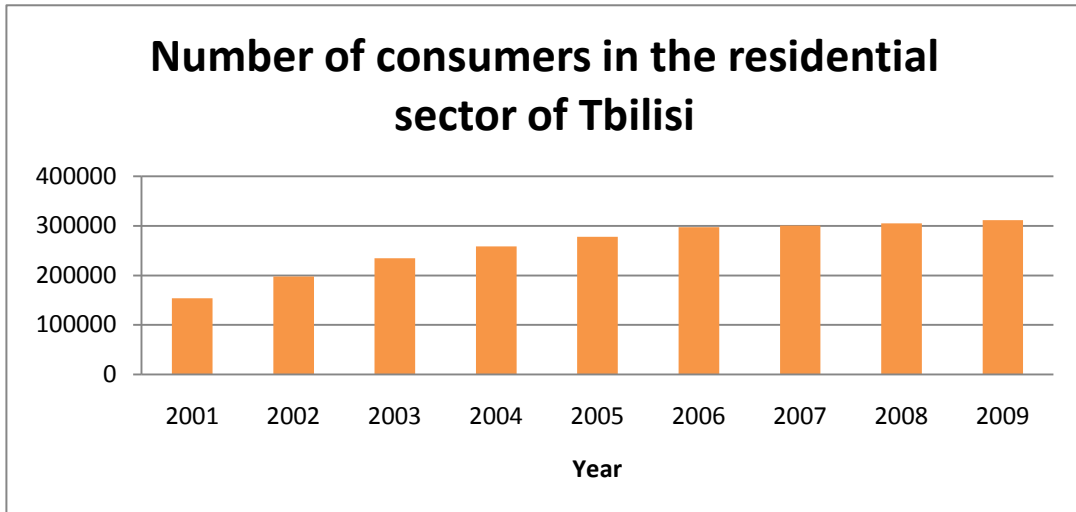

Figure 3.4 The number of gas consumers in the residential building stock of Tbilisi

Numerical values from Tables 3.3 are presented in the form of diagrams below in Fig.3.5-3.6.

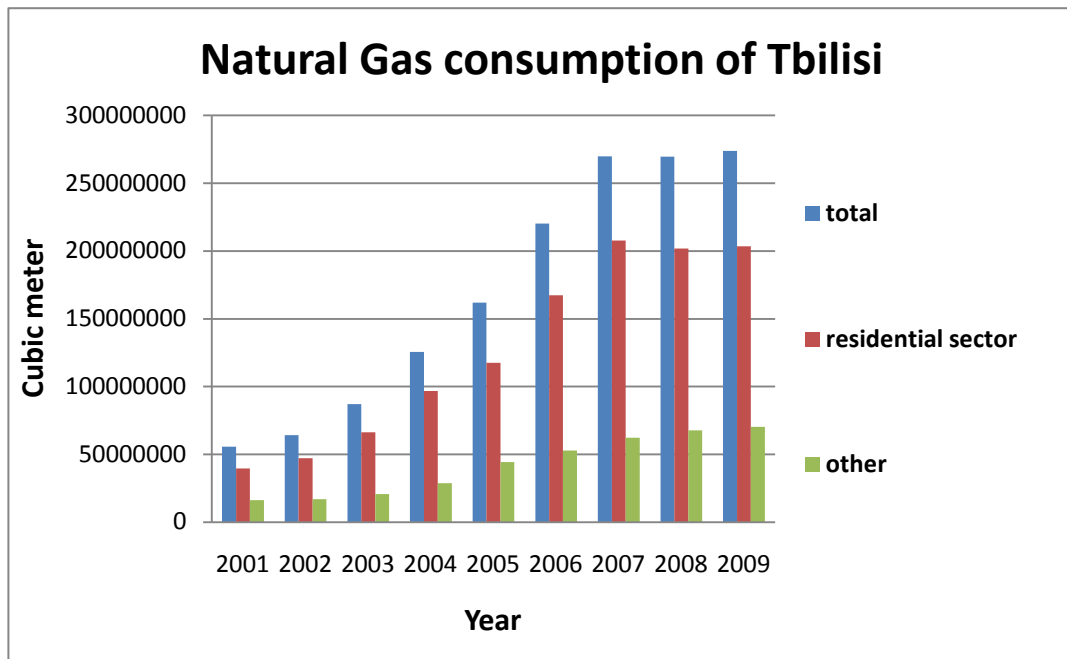

Figure 3.5 Diagram of the natural gas consumption in cubic meters in Tbilisi

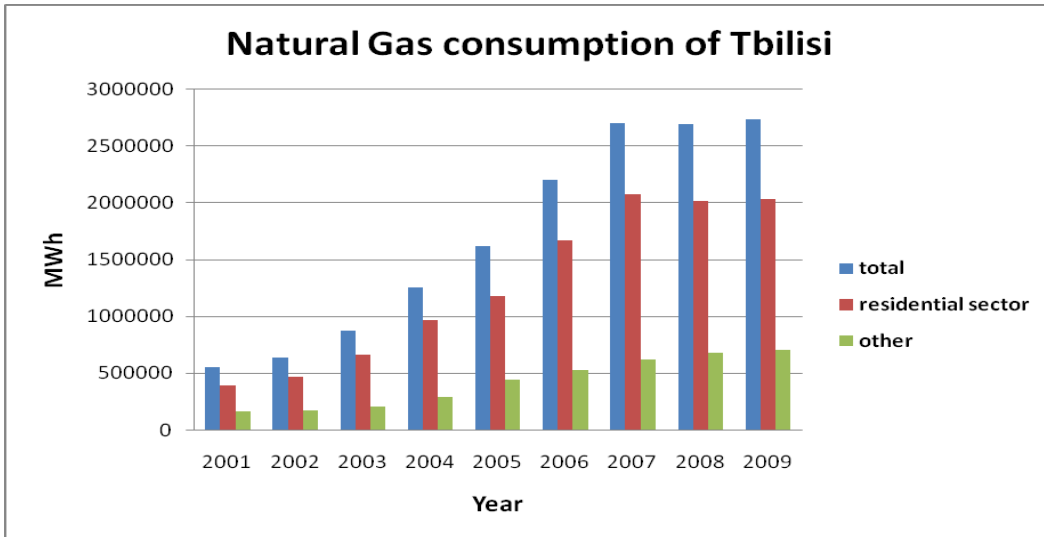

Figure 3.6 Diagram of the natural gas consumption in mWh in Tbilisi

Diagrams presenting dynamics of annual natural gas consumption by districts are given below in Figures 3.7 - 3.18

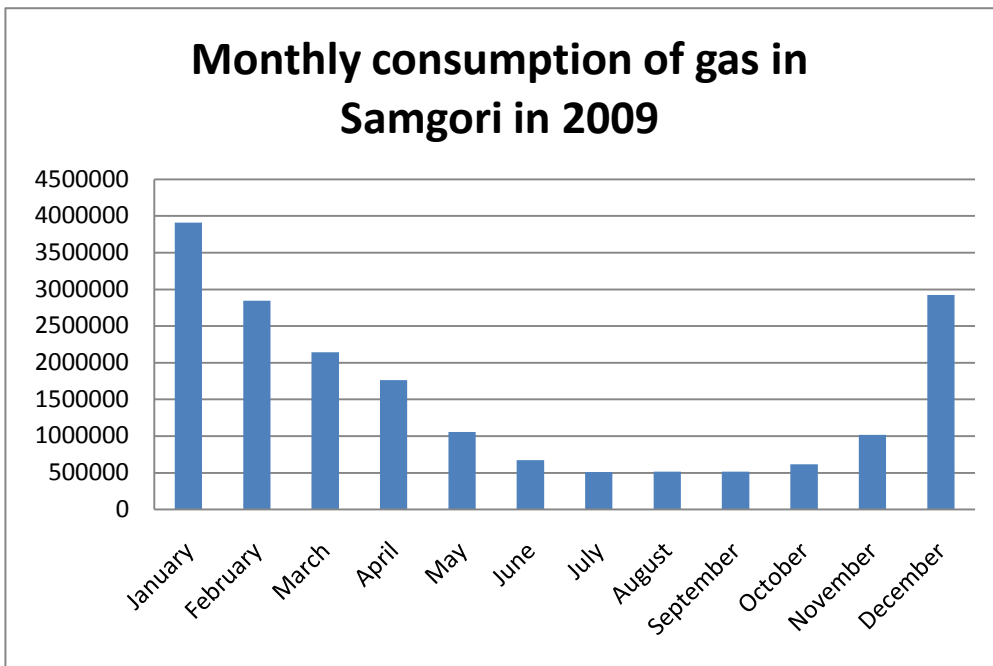

Figure 3.7 Gas consumption in the Samgori district

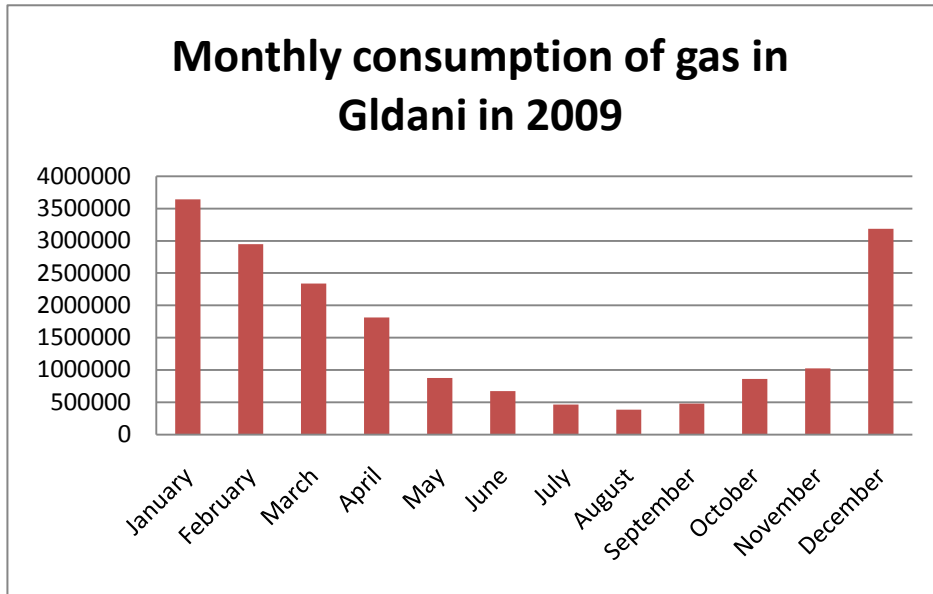

Figure 3.8 Gas consumption in the district of Gldani

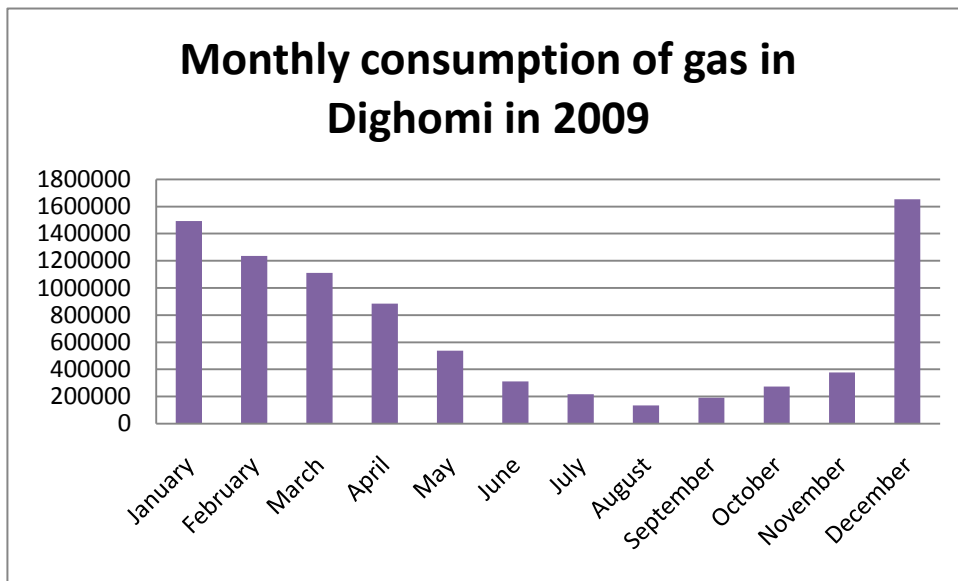

Figure 3.9 Gas consumption in the Dighomi district

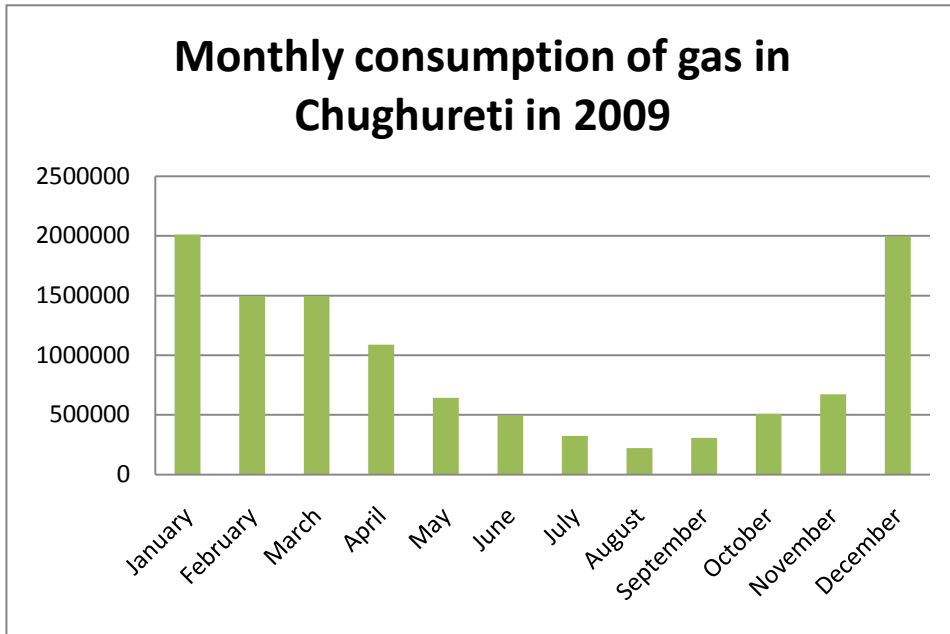

Figure 3.10 Gas consumption in the district of Chugureti

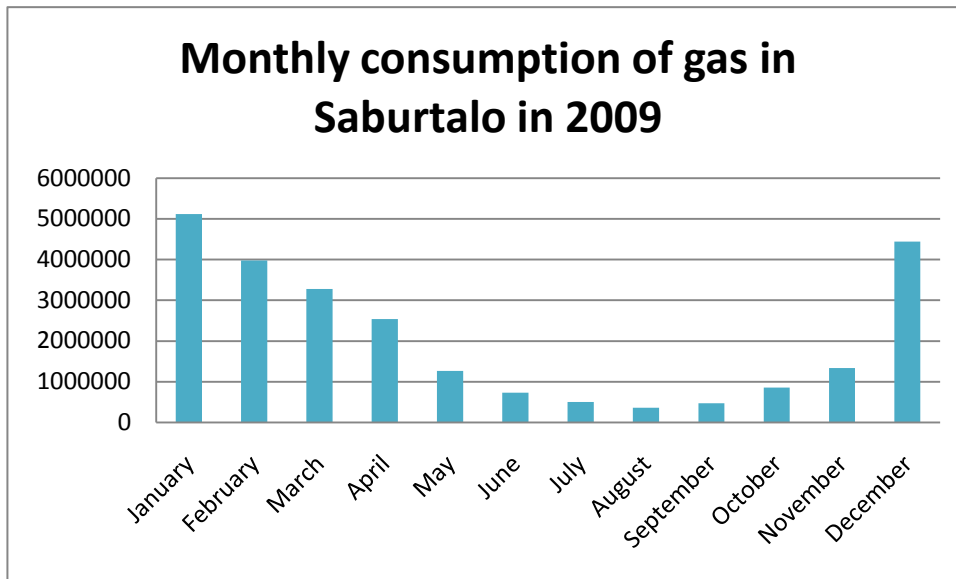

Figure 3.11 Gas consumption in the Saburtalo district

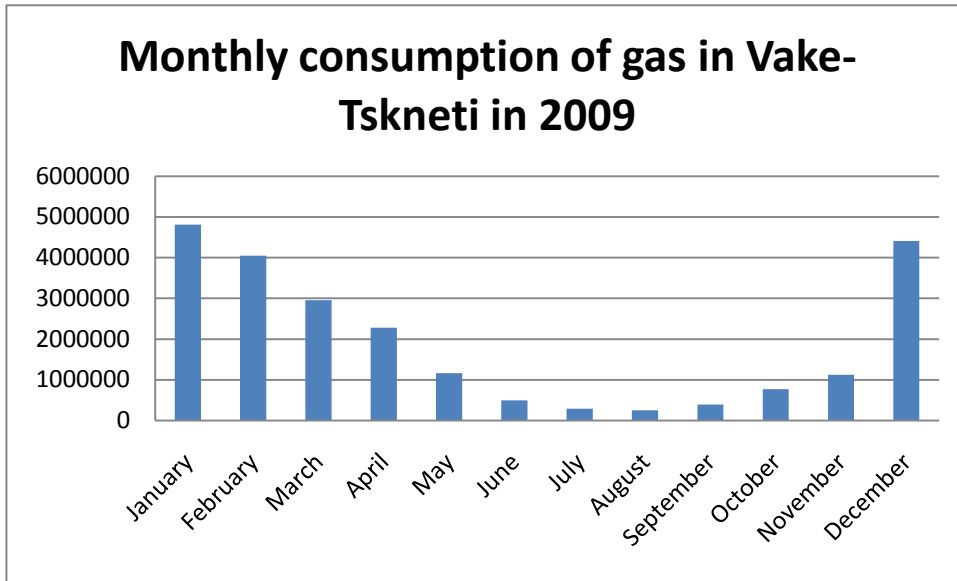

Figure 3.12 Gas consumption in the Vake - Tskneti district

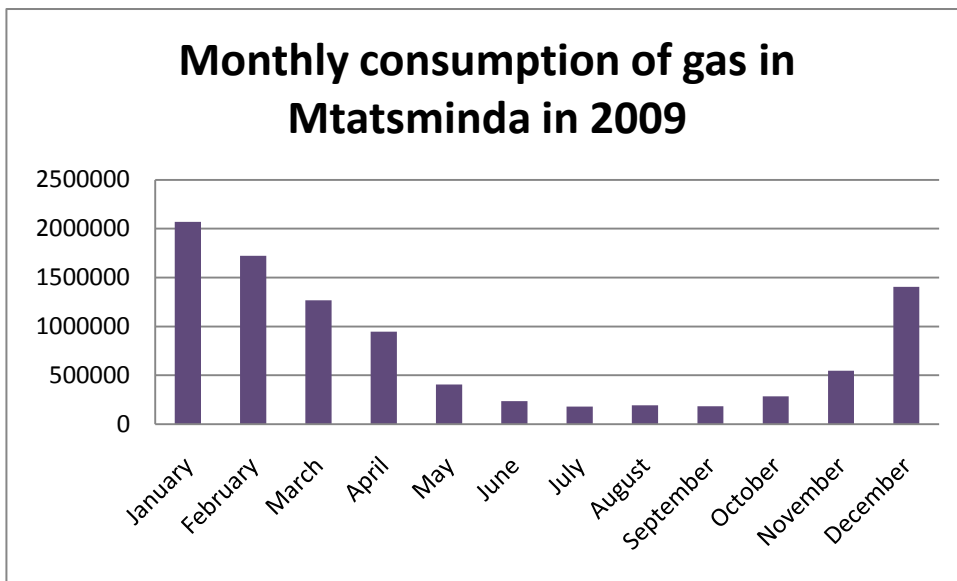

Figure 3.13 Gas consumption in the district of Mtatsminda

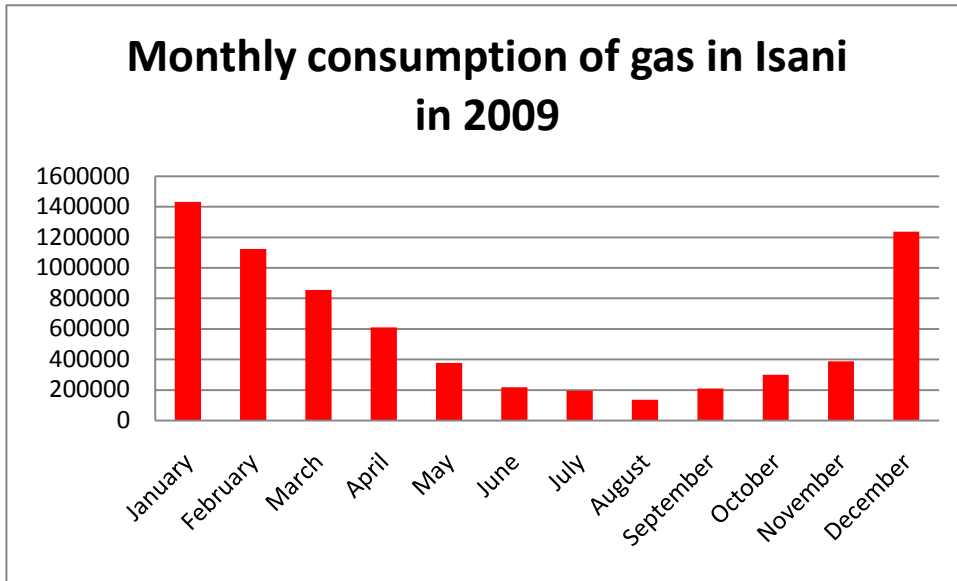

Figure 3.14 Gas consumption in Isani district

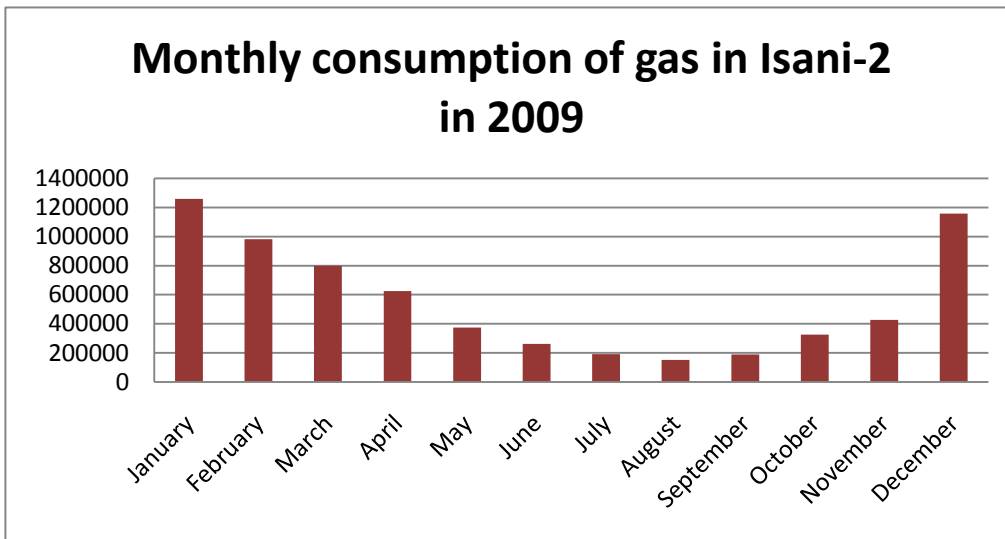

Figure 3.15 Gas consumption in Isani-2 sub-district

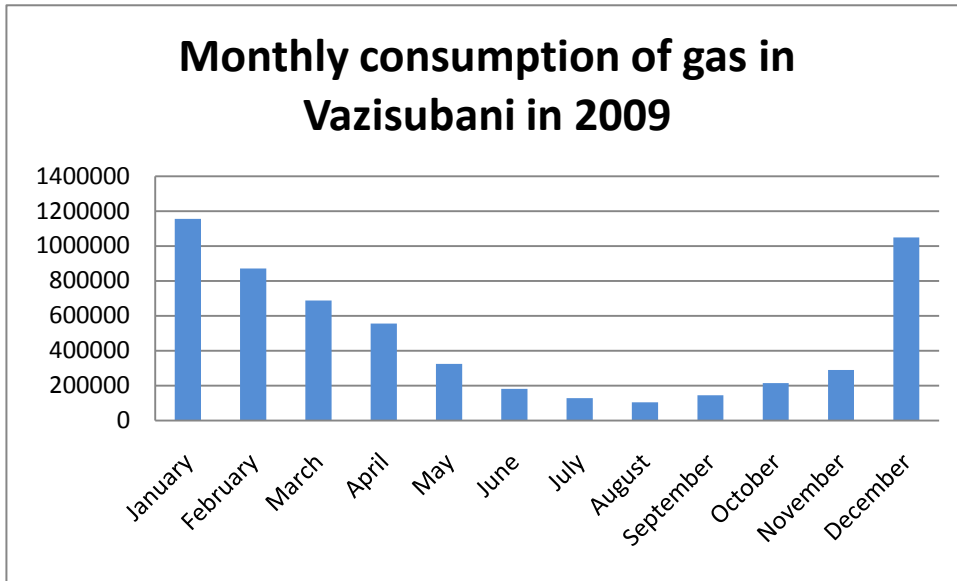

Figure 3.16 Gas consumption in the Vazisubani district

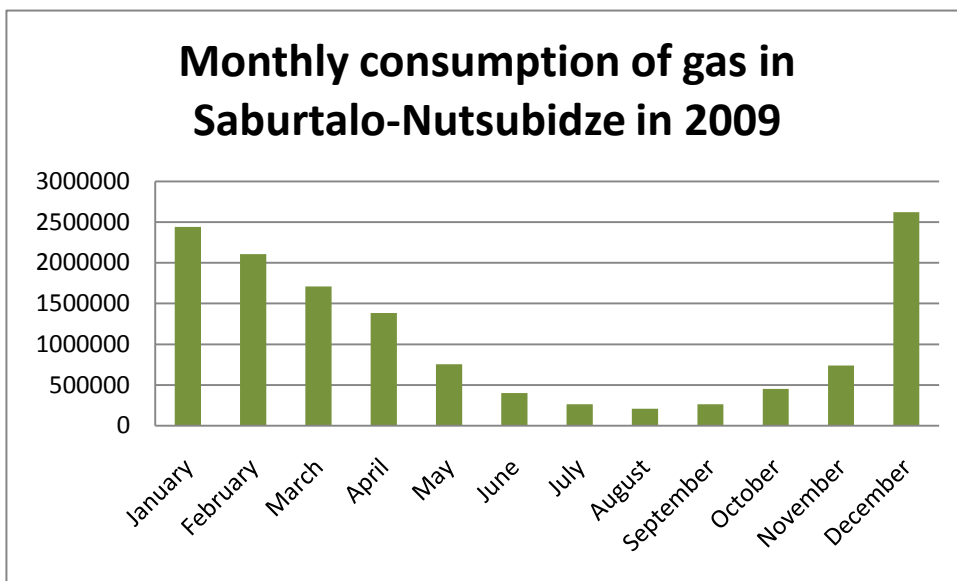

Figure 3.17 Gas consumption in the Saburtalo-Nutsubidze sub-district

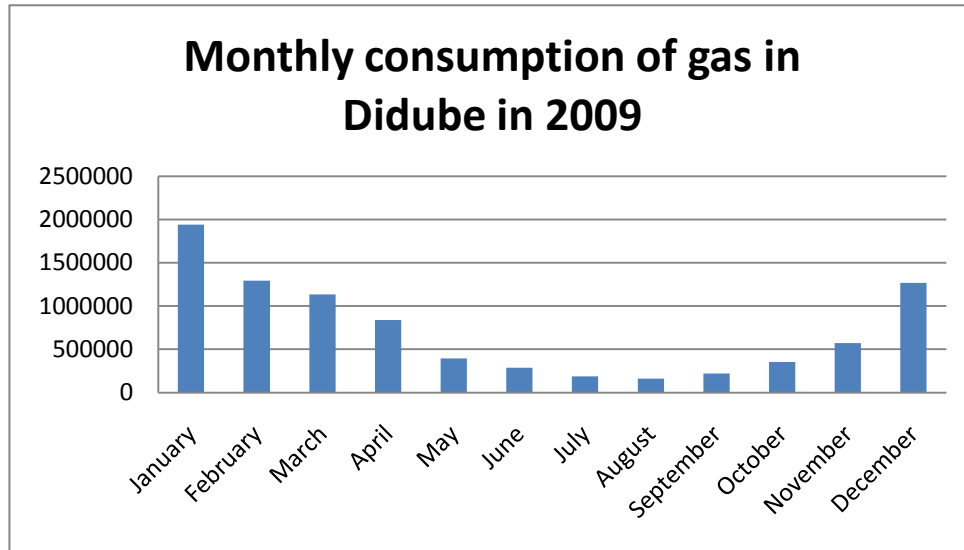

Figure 3.18 Gas consumption in the district of Didube

Figures 3.7-3.18 illustrate 3.5- to 5-fold growth of gas consumption in Tbilisi districts on average during winter months. This indicates that natural gas is the major energy carrier used by residents for heating purposes in the winter period.

2.2. Baseline Emissions Inventory

The sustainable development concept introduced by Gro Harlem Brundtland as a new concept for growth defines future development as an integrated approach considering all its dimensions such as economic, environmental, and social as interlinked and inseparable “paths of progress that have to meet the needs of the present generation without compromising the ability of future generations to meet their needs”.

Under the sustainable development concept strong attention is given to issues of sustainable energy, considering energy efficiency and renewable energy as its twin pillars. Thus, it has already been recognized by all parties that anthropogenic global warming is occurring and our climate is changing, due to the growth of CO₂ emissions as a result of economic activities.

Under the Kyoto protocol many countries are committed to reduce their greenhouse emissions. One of the goals of Kyoto is to see participants collectively reducing emissions of greenhouse gases. The importance of strong political decisions for the stabilization of this process on our planet and the adjustment of proper environmental management is stressed.

The European Union is leading the fight against climate change and global warming. The Covenant of Mayors is the first European Commission initiative directly targeting local authorities and their citizens to take the lead in the fight against global warming and to meet Kyoto's objectives.

The Tbilisi City Hall displays an active, positive attitude and is wholly committed to turn Tbilisi into an energy efficient city. As was already noted, the buildings sector is believed to be one of the areas with a high energy savings potential.

A greenhouse gas emissions inventory for buildings in Tbilisi was prepared as a part of the sustainable energy action plan, including an analysis of energy consumption and the consideration of ways of optimizing energy consumption in the buildings sector and limiting CO₂ emissions. In order to calculate the baseline emissions from buildings, the energy consumption structure in the residential sector in Tbilisi was reviewed and analyzed along with the basic electricity and natural gas consuming appliances and end use systems. The LEAP software program was used for the assessment of the baseline emissions inventory (BEI) for buildings sector. 2009 has been taken as the baseline year in this program with the purpose of identifying CO₂ emissions as well as forecasting emissions up to 2020. The methodology for calculating the CO₂ emissions is based on the assessment of energy end use technologies as well as consumption trends which utilize data and findings provided below.

2.2.1. Energy End Use Technologies, Consumption Trends and Analysis for Calculation of CO₂ Emissions

The electricity consumption structure in the residential sector of Tbilisi varies to a great extent depending on the consumers' category, thus affecting the energy efficiency, means, and ways of its improvement. For instance, the poorest group of consumers (5-100 kWh of consumed energy per month) makes up 36% of all consumers in Tbilisi and spends about half of all consumed energy on lighting and 25% on electric heaters; i.e. 75% of the total.³⁷ The next largest item is the refrigerator at 11%, followed by the TV at 5% and irons at 4%.

In the 101-300 kWh category (just 10% of all customers) lighting also consumes half of electricity usage, followed by the refrigerator at 17%, electric water heaters (absent in the previous category) at 10%; i.e. 77% in total.

³⁷ 14% of all households consume less than 5 kW per month and represent uninhabited flats.

In the category of 301+ kWh the greatest energy consumption is from electric water heaters at 31%, lighting at 24%, electric heaters and refrigerators, each at about 13%; 81% in total. Sophisticated household appliances like washing machines, air conditioners, PCs follow with about 3% for each and play very little part in the energy consumption; they accordingly have very small energy efficiency potentials.

The last category is the largest, representing 40% of all consumers, followed by the least consuming group (5-100 kWh). The 101-300 kWh category may be considered as transitional between the poor and the affluent. Depending on economic circumstances people from this category may move either upward or downward.

People in the 301+ kWh category consume the bulk of energy in all electrical equipment groups save for lighting, where they consume 48% of electricity. If compared on a typical household versus typical household basis, they consume between 62-65% of the energy used for refrigerators, TV, and PC, 68% of air conditioners, 76% of electric space heaters, and 89% of electric water heaters. Among other things this means that the real efficiency improvement potential may be found in this category of consumers.

Electricity Consumption of the Residential Sector of Tbilisi in 2009 Constituted:798.03 mln kWh

	Energy efficiency rates for electrical equipment in residential buildings												
Electrical equipment types for average electricity consumer categories	Lighting	El. space heaters	El. water heaters		Refrigerators		TV (LCD- LED –90 to 100 cm)	PC	Iron	Washing machine	Air conditioner		Other
			Tank type	Tankless	One door free-standing with freezer	Two door refrigerator freezers ≤ 180 cm					EER	COP	
El. consumption structure (%)	33	11.2	23		14		3.5	3.3	3	3.6	2.7		2.7
En. Ef. Rates for conventional/inefficient Equipment	incandescent bulbs 0.13 ÷ 0.14	0.95	0.87	0.88	0.18	0.18	0.17	0.7- 0.75	n/a	≤0.25	≤0.22	≤0.24	n/a
En.Ef. Rates for modern/efficient equipment	compact fluorescent 0.56 ÷ 0.69	1.0	0.92- 0.95	0.98	33.3	3.3	0.31	≥0.8	n/a	≥0.52	≥0.32	≥0.36	n/a

Note: the energy efficiency rates in the above table are mainly complied on the basis of the EU Energy Label program. This program is the most comprehensive of all, which is available today worldwide. Still it provides different versions of energy efficiency calculations. In some cases efficiency is defined as the ratio of useful output per unit of energy, while in others it is the function of energy used to provide a unit of useful output. To make these data directly compatible some efficiency indicators (namely refrigerators, TV, washing machines, air conditioners) were provided as a reciprocal value (i.e. 1/actual indicator) and some values were adjusted in order to keep them within the 0-1 range, where 1 is the most (100%) efficient.

Energy Efficiency calculation for lighting

Category Lighting	Lamp type	Power consumed per hour/ bulb (in Watts)	Light Produced (in Lumens)	Average life time per Lamp (in Hours)	Efficiency
1.	Incandescent	60W	800	1000	$800/60=13.3$
2.	Compact Fluorescent (CFL) Warm White (2670K)	13 W	900	10000	$900/13=69$
3.	Incandescent Halogen PAR 38 Flood	100W	1400	2000	$1400/100=14$
4.	Compact Fluorescent PAR 38 Flood	23 W	1300	6000	$1300/23=56$

Lighting

As the previous review of energy consumption in the residential sector shows, lighting is the largest single consumer of electric energy in Tbilisi households. It is especially important for the relatively less affluent stratum of the population, who consume less than 300 kW of electricity per month.

Reaching an energy efficiency solution in this case is a pretty simple and straightforward process with the replacement of old incandescent bulbs with modern, compact fluorescent ones. In such a case lighting efficiency increases 4-5 times (see table) with a corresponding reduction of energy consumption and expenditures.

At the same time, according to the expert's evaluation, currently about *25-30% of consumers in 101-300 kW category and about 15-20% of consumers in the 300+ kWh category use CFL bulbs* for lighting purposes. The poorest consumers hardly use such efficient bulbs at all. There are a number of reasons for this:

CFL bulbs on the local market cost at least 8-10 times more than incandescent bulbs providing the same light. For households (especially the poorer ones) a one-time investment in very expensive efficient bulbs is more difficult than the gradual replacement of cheaper ones, even if they lose money in the long run.

Under the local conditions the efficient lifetime of CLF bulbs is usually relatively less than publicized, which also makes potential customers vary in their use. This is caused both by the abundance of low quality (often counterfeit) products on the local market as well as by frequent fluctuations of in the electric current, which also affects even the best CLF bulbs in a negative way.

As world experience shows, under such conditions it is feasible to distribute energy efficient bulbs free of charge or at least at heavily subsidized prices through a government program, as is done in the UK for instance. This may apply only to the poorest consumers, who constitute about 2/5 of all active consumers in Tbilisi, but will at least create the interest and show the advantages of energy efficient bulbs versus the traditional ones. Another way is to prohibit the use of traditional bulbs by law, as Russia aims to do; although this is less feasible. Efficient quality control both at electricity and appliance markets will also help greatly.

Energy Efficiency for Electric Space Heaters

Although in total electricity consumption electric space heaters occupy the third place after electric water heaters in Tbilisi, they play an important role in electricity consumption of the poorest households. Interestingly, electric heaters also play an important role in the electricity consumption of the upper stratum of consumers. In both cases consumers spend about half as much on such heating as they do on lighting.

The majority of electric heaters use one of two processes to heat a room, namely convection or conduction. Convection heaters heat the air and circulate it around the room, providing gradual heat. Many convection heaters use a fan to physically push air around the room, whilst others rely upon rising hot air to circulate warmth.

Conduction heaters, conversely, uses radiant heat to warm objects directly, rather than indirectly heating the air. This direct heating action, provided by exposed elements, ensures that conduction heaters are unaffected by drafts, and provide focused and intense heat. Oil radiators, which are very popular in Tbilisi, provide a more regular level of heat because, although the heating element may go on and off several times an hour, the oil buffers the extremes of temperature of the heating element, so that consumers get a more steady temperature coming

from the heater. So most electric heaters are energy efficient electric heaters - *100%* efficient in the case of heaters without a fan - in the sense that all the electricity input is turned into heat. When the fan is factored in the efficiency is still in the range of *95-98%*, as the fans consume very little energy compared to the kilowatts consumed by the resistant heating element.

Obviously there is no way to make such heaters more efficient *per se*, but they are less efficient compared to natural gas heaters, taking into account the relative price of electricity and gas. There are a number of reasons why electric heaters are still more widespread than the gas ones.

First, a change to gas heating means either the installation of a conventional gas heater or space water heating. In the first case expenses run as high as 400-500 GEL or more. This is rather high for the vast majority of households, who consume less than 100 kW per month. Besides this even the most efficient gas space heaters available on the local market can only heat one continuous space efficiently. Thus for a multi-room apartment more than one heater is needed, but installing the additional gas supply mains is quite difficult and hardly ever recommended.

The price of installing space water heating runs into the thousands of GEL, making such service available only for the most affluent. Also, the installation process itself often leads to a major refurbishing of the whole flat (or house) pushing expenses much higher. In addition, among post-Soviet residential buildings ones where walls have insulation properties in compliance with even the old Soviet norms are a rare exception. Thus in many cases even properly functioning space water heating is not enough to provide comfortable conditions in new houses and electric space heaters are widely used for provision of additional heat. This mainly explains the wide spread use of such appliances in the highest energy consuming stratum of the population. The case where the largest common room is heated continuously during the day by a gas space heater and other rooms by electric heaters, when such need arises, are also wide spread.

One more indirect way to improve the efficiency of 100% efficient appliances is to upgrade the thermal properties of the premises, which they heat. This is rather expensive (including the installation of new metal-plastic double glazed windows, for instance) and not often accessible for the local population.

There is little room for improvement in this sector of electricity consumption both from a technological and organizational point of view. Of course, electric heaters are being replaced by cheaper and more convenient gas ones, but this is a rather slow and gradual process.

Electric Water Heaters

The Energy Factor is the ratio of useful energy output from the water heater to the total amount of energy delivered to the water heater. The higher the EF is, the more efficient the water heater. Tank-type water heaters, which are the most common in Tbilisi, used to have an EF of about 0.80-0.86 before 1991, but such were hardly available in Georgia and the vast majority used now are from post-1995, with a minimum EF of 0.9. The best water heaters available now have an energy factor of 0.92 to 0.95, with larger models (80 liters or more) being relatively less efficient than smaller ones (40 liters), which are the most widely used. Tank-type water heaters available on the local market are mainly represented by Ariston or Thermex models, which are in compliance with existing EU standards, thus leaving rather little room for improvement of such appliances. The same can be said about modern tankless water heaters. Many people (in the case of tankless heaters one may say the majority) still use small heaters of local manufacturing, which can not be even properly rated since no proper documentation is available for them. They are obviously extremely inefficient compared to the modern, imported ones, but here again the price plays the decisive role, since they are ten or more times cheaper than the efficient ones. It is fair to assume that such tankless heaters are mainly used by the relatively less affluent category of consumers, present in the 101-300 kW stratum, who on average use just about 12% of all electricity consumed by electric water heaters.

As in the previous case, a shift from electric to gas heaters is the sensible solution for any household. Although the energy factor of on-demand tankless gas heaters is considerably lower than that of electric heaters (0.5-0.7), gas is so much cheaper than electricity, that this outweighs any over considerations.

Tank water heaters are still widely used in Tbilisi for heating water for bathrooms. The layout of Soviet period flats was such that gas could be used only in kitchens but not in bathrooms. To use gas heated water in the bathroom one has either to:

- install space water heating, with all the consequences described above
- install a water heater in the kitchen and install a hot water pipe to supply water to bathroom (inconvenient and expensive)
- install an additional gas supply line in the bathroom (if such is technologically permissible), but in Georgia such installation is prohibitively expensive even for affluent households.

With all factors taken into consideration, tank electric water heaters will be the most popular means of hot water supply in the foreseeable future, costing the population much more than gas heaters with marginal efficiency improvements due to general technological development. Although again, such are seldom available for the poorest.

Refrigerators

The energy efficiency index for refrigerators is calculated for each appliance according to its consumption and its compartments' volume, taking into account the appliance type. The index is thus not calculated in kWh. The two most commonly used models of refrigerators are one door free-standing with freezer and two door refrigerator freezers less than 180 cm high. In Europe the inefficient one-door models are characterized by 54.4% efficiency, while the efficient models by manufacturers available in Georgia (Bosch/Siemens, Electrolux, etc.) have an efficiency of 29.6-29.8%. As for two-door refrigerators, the inefficient models are characterized by an index of 54.7%, while efficient ones are 29.8-30.0%. In Tbilisi the majority of refrigerators used by the least consuming stratum are represented by one-door models, often the obsolete Soviet ones. The efficiency index for such can't even be calculated, although obviously they are extremely inefficient compared with modern ones. On the other hand all of them are at least 20 years old and are gradually being phased out. The cheapest very small one-door refrigerator available on the local market costs around 380 GEL, larger ones start at 450 GEL, and two-door models from 750 GEL. Thus even for poor households the replacement of an old refrigerator is possible, even if difficult undertaking. However these consumers use just about 7% of all energy spent on refrigeration and make very little impact on energy efficiency of this consumption category.

Televisions

Unlike other household equipment, energy consumption by TV sets is growing over the years, since higher quality TV sets require more energy. For instance, the average plasma TV consumes 301 watts, whereas the average LCD (standard) consumes 111 watts and the average LCD (LED) consumes 101 watts. Though the most expensive and energy consuming TV sets are not common, and the least energy consuming ones – the smallest and the most wide spread, consume much less energy compared to other energy consuming systems existing in households in Tbilisi. Even the most expensive TV models consume (depending on the screen size) energy comparable with the average electric bulb, ranging from 40 to 300 watts. Thus, the real energy savings in this segment comes only when one replaces old Soviet TV sets with modern ones.

Although the price of CRT TV sets on the local market is rather low and they are within reach of almost every household, save the poorest.

LCD-LED TV: a 90-100 cm inefficient model consumes power at around 115 W, while the most efficient model consumes around 62 W. The smallest CRT TV available locally consumes 65 W, and the largest consumes 117 W.

There is a rather small margin for energy efficiency improvement in this sector, since TV sets consume just 3.5% of all electricity. The real savings may be achieved only by phasing out the old Soviet manufactured sets, which are still used by many of the poorest families, and the old imported ones. Such old TV sets are bought from the population, refurbished, and then sold back for a price less than half of the cheapest new ones. But again, the poorest consumers use about 12% of all electricity spent on TV. Another way is to teach people not to leave TV sets in sleep mode at night or when no one is at home and to turn them off completely in order to save energy.

Electric Irons

All new models of electric irons worldwide are rather similar and consume 1-1.8 kilowatts of energy depending on the quality. There is just one way of saving under the local conditions - by replacing the old Soviet irons with modern ones, although such are rather scarce today.

Washing Machines

The MEF represents how energy efficient a model is. The clothes capacity, electrical energy consumption, hot water energy consumption, and energy required for drying are all factored into the equation. The resulting numerical figure is the MEF. To be an Energy Star appliance, a washer has to have a minimum MEF of 1.8. Starting from January 2011, the minimum went up to 2.0. Higher MEF values mean more efficient washers. The minimum acceptable MEF in the US is 1.42. Washing machines account for about 3.6% of all electric energy consumed in Tbilisi and are usually available for relatively affluent households, save the rare cases when someone has retained the old Soviet machines, which are more than 20 years old. Washing machines available on the local market are usually of energy class A, meaning that they should consume less than 0.19 kWh per kilogram of washing, while the least efficient (of class G) consume more than 0.39 kWh. Thus there is a small margin for energy efficiency improvement, save for the cases in which households possess old imported washing machines, which are naturally less efficient than modern ones. The problem is that such machines are extremely durable and work

well even after 20 years of use (for instance various Siemens models), thus owners are reluctant to part with them and invest heavily in a new one. Of course these machines could be replaced by more efficient ones through some old appliance utilization program, if such a program would be considered feasible. According to the expert's evaluation, old inefficient washing machines may be present almost in all households consuming 300 or less kWh per month, which accounts to about 38% of all electricity used for these appliances. Thus there is a rather big margin for efficiency improvement in this category, but it may have a very small overall efficiency impact, accounting for just about 1.4% of total household electricity consumption.

Air Conditioners

Air conditioners still represent a luxury item and consume just about 2.7% of electricity in Tbilisi. An improvement in this sector may come again from replacing old Soviet air conditioners, but this is rather difficult, since there is a market (as in case the of TV sets and refrigerators) for used ones, which are refurbished and then sold at a price at least 4 times less than the cheapest modern split systems (available at around 800 GEL). One may assume that such old, inefficient air conditioners are present *en mass* in the categories below 300 kWh, who spend about 32% of total air conditioning electricity. Thus there is definitely room for improvement, even if in absolute terms, comprising just 0.9% of all consumed electricity.

Among the modern split systems with less than 4 kW power, inefficient ones have a cooling capacity of 3290 W, while efficient ones are around 2000. The heating capacity correspondingly is 3580 and 2500 W. The electricity consumption for cooling/heating is (kW/year) – 389/1638, 124/616.

The Energy Efficiency Ratio (EER) of a particular cooling device is the ratio of *output* cooling (in Btu/hr) to *input* electrical power (in Watts) at a given operating point (indoor and outdoor temperature and humidity conditions). To qualify for the European energy label air conditioners should have a minimum EER of less than 2.2 (category G), while category A requires a ratio of more than 3.2. The heating efficiency of air conditioners is measured by the coefficient of performance or COP, of a heat pump, which is the ratio of the change in heat at the "output" (the heat reservoir of interest) to the supplied work. In European labeling, the COP changes by more than 3.6 for class A (although some units have an EER and a COP of more than 5) to less than 2.4 for class G. Unlike the majority of other appliances, air conditioners sold in Georgia are not labeled, thus it is difficult to define how efficient they actually are.

Personal Computers

The typical power of personal computers (PCs) ranges from 500 W to lower than 300 W for small form factor systems intended as ordinary home computers. The use of such computers is commonly limited to web-surfing, burning, and playing DVDs. Laptops consume even less energy, ranging from 25 to 200 W. Computer power supplies are generally about 70–75% efficient. That means in order for a 75% efficient power supply to produce 75 W of DC output it would require 100 W of AC input and the remaining 25 W of energy would dissipate in the form of heat. Higher-quality power supplies can be over 80% efficient; higher energy efficient PSUs (PSU is a device that converts AC voltage to DC ones needed by a personal computer) waste less energy in heat, and require less airflow to cool, and as a result will be quieter. The US Energy Star program requires that PCs should be 80% efficient to qualify. There is almost no room for improvement in this category of consumption. There are virtually no relatively old PCs with higher energy consumption than is considered efficient. These appliances are replaced rather often and improvement here goes hand in hand with general global trends.

Annual Electricity Consumption by Consumers of Different Categories (kWh per appliance)

Consumer Group (kWh/month)	Lighting	El. heater	El. water heaters	Refrigerator	TV	PC	Iron	Washing machine	Air conditioner	Other
5-100	393	195	0	88	39	0	29	15	0	29
101-300	1160	51	240	385	80	105	50	110	78	40
≥ 301	1444	764	1842	792	197	192	91	200	168	314

Source: Energy Efficiency Potential in Georgia and Policy Options for Its Utilization

Prepared by World Experience for Georgia for Winrock International under the Sub Agreement 5708-07-04
February 2008, 5.12

The Estimate of Natural Gas Used for Heating, Cooking and Hot Water Supply in Tbilisi

Number of Customers	Total Consumption GWh/year of which:	Cooking GWh/year	Heating and Hot Water Supply GWh/year, of which:	Hot Water Supply GWh/year	Heating GWh/year
304500	183.5	72	112	22.3	89.2

Source: Energy Efficiency Potential in Georgia and Policy Options for Its Utilization

Prepared by World Experience for Georgia for Winrock International under Sub Agreement 5708-07-04 February 2008, 5.16

The share of residential sector in natural gas consumption in Tbilisi is considerably higher in its electricity consumption – 74% versus 52%.

Natural gas usage is also more straightforward than electricity and covers much less applications and devices.

Cooking consumes about 40% of the total gas consumption in the residential sector, while heating and hot water supply cover the rest. The hot water supply uses 12% and heating uses 48%.

	Energy Efficiency Rates for Gas Appliances in Residential Buildings			
Gas Appliance Types	Gas Hobs	Tankless Gas Water Heaters	Gas Boilers	Gas Heaters
Gas Consumption Structure (%)	Cooking	Hot Water 12		
	40		Heating 48	
En. Ef. Rates for Conventional/Inefficient Equipment	0.55	≥ 0.82	≤70	≤78
En. Ef. Rates for Modern/Efficient Equipment (maximum possible)	≥0.55	0.95	0.98	0.87

Gas Hobs

Little can be done in reducing the consumption of cooking gas, since gas burners are pretty inefficient in principle. They are 55% efficient, meaning that they use only this amount of produced energy. They are not even formally rated like other household appliances (refrigerators, electric ovens, etc.). In addition, traditional electric cook tops are only marginally better, with 65% efficiency. The only really effective cooking appliance today is the induction stovetop with 90% efficiency, but it is so expensive that it is rarely purchased or used despite having been on the market for decades. The only recommendation made for Western consumers in such a case is to replace the old-style pilot flame burners with the new ones with piezoelectric ignition. Stovetops of this kind – with pilot flame - are not present in Georgia at all. One can find two extremes regarding gas hobs in Tbilisi – they are either old (sometimes dating back to the 1960s) Soviet made appliances or modern ones, with Bosch/Siemens/Gorenje at the top of the price-range and Beko/Vestel for less affluent consumers. Most of the best ranges have a piezoelectric ignition. The majority of these are also equipped with electric ovens, which invariably are publicized as A-class efficient. The process of replacing old appliances is ongoing, reflecting their physical deterioration.

Tankless (on demand) Gas Water Heaters

Tankless (on demand) gas heaters are a common choice for hot water, but they are much less popular than electric ones (due to problems described above). The minimum efficiency rating for such heaters in the US (for example) is ≥ 0.82 , where 1 denotes absolute efficiency in a device. In some cases the population will purchase highly efficient Ariston models, but the real problem particular to this type of appliance is that there are numerous low-quality, cheap heaters, which are not provided by any reliable suppliers or sold in brand shops. More often than not these devices have been installed by unqualified personnel, in places where it should be prohibited to install them. Thus, these devices often malfunction and fatalities are routinely reported.

Gas Heaters

From the heating point of view the situation is more complicated. The least affluent (most likely the same people who consume less than 300 kWh of electricity per month) mainly use small open-fire gas heaters for heating. Such appliances are formally prohibited in Georgia, since they are extremely hazardous, but they are still rather openly sold and widely used, because they are

very cheap. They are characterized by incomplete gas combustion, oxygen consumption in rooms where they are installed, methane concentrations, no safeguard mechanisms, etc.³⁸

There are a considerable number of fatalities connected to using gas heating appliances in Tbilisi, particularly with the Iranian-made Nikala brand heaters, which are not sold any more, but are still used in large numbers.³⁹ Phasing out these appliances is a problem for the local gas supply company (Kaztransgas); a step which will increase efficiency of gas application for heating, besides improving gas application safety.

More affluent consumers mainly use the Czech-made Karma gas heaters. These devices are safe and claim 87% efficiency, which is high by current standards (the US law requires gas heaters to be at least 78% efficient, while some models have ratings as high as 97%). They are usually installed in one room of the flat, while other rooms are heated occasionally by electric heaters. There are some other brands available on the Georgian market as well (like Longvie), but they all claim about the same level of efficiency. The main problem associated with using such heaters (as well as gas appliances in general) is that the natural gas supply system in Tbilisi was designed for satisfying the needs of cooking appliances together with the occasional small water heater. The designed gas pressure in this system is considerably less than is necessary under the current conditions, where a number of various gas appliances might be simultaneously used in one household. As a result, gas pressure fluctuations are rather common, leading again to incomplete combustion and a corresponding drop in efficiency of even the most sophisticated appliances. Although products of such incomplete combustion do not penetrate rooms, where these heaters are installed, they add a considerable amount of unwanted CO₂ and methane to the atmosphere.

There are some other reported problems, both regarding the reliability and safety of these heaters, but they are mainly connected to improper use and installation of such devices by unauthorized personnel (which is cheaper).

As in the case of electric space heaters, the main problems associated with such gas heaters lies not in the efficiency and reliability of heaters *per se*, but rather in the environment in which they operate. The areas in which such heaters are used are almost always poorly insulated, containing single-glazed windows with old, wooden, deformed frames, and walls which can not

³⁸ Besides being hazardous to health, methane is a highly potent greenhouse gas. 1 kg of it equals 21 kg of CO₂.

³⁹ Many heaters used by poorer consumers are simply homemade, consisting of steel pipes (sometimes looped) with holes, inserted into extremely primitive wood stoves.

provide sufficient insulation. As a result, a majority of the energy is being spent on overcoming these deficiencies rather than performing proper functions. Thus, the actual outputs of relatively high and low performing heaters are often factually leveled out.

Gas Boilers

Central heating boilers are also used in Tbilisi. Though, like other appliances of this type, they can be divided into two pretty widely differing groups. At one end there are numerous old, Soviet-made АГВ tank boilers, which were installed virtually in every individual house in the city. Plenty of these models date back to the 1970s. With proper maintenance (and some luck) they are virtually indestructible and still perform their functions. They are obviously inefficient to the extent that even the current European G level of efficiency (the lowest grade, below 70%) seems to be high for them.⁴⁰ On the other hand their owners, even if rather wealthy, have no incentive to replace them as long as they are operational. Installing a modern efficient system is expensive to the extent that losing money on the old system seems to be a preferable solution in the long run. This situation certainly calls for a government-sponsored boiler scrappage scheme.

On the other end of the spectrum there are highly efficient boilers being installed mainly in new houses and apartment buildings, providing both hot water and heating. The best of these are presented by Buderus, Lamborghini, and Ariston brands with a declared efficiency of 95 to sometimes even 98% - factually the highest possible today. The lower end of the range is presented by the Turkish-made Vestel brand, which nevertheless displays A-rate efficiency on its products. Here again, the problem is that in the vast majority of cases these efficient heating systems are installed within areas where the walls can't provide the minimum standards of thermal performance. It is commonplace to find situations in which the heating leads to condensation on the walls, even in the most expensive of new houses.

2.2.2. Household Baseline Inventory and BAU Scenario Development

Methodology

LEAP, the Long Range Energy Alternatives Planning System was used for household BEI and BAU scenarios. Detailed description of leap is provided in Baseline Inventory of the transport Sector (p.22).

⁴⁰ The maximum - A - is 90% and higher.

The structure of the Tbilisi Household Sector (Current Accounts)

LEAP is a bottom-up, demand driven model. The structure of the energy sector in this model consists of three subsectors, these are:

- Energy Demand Sector
- Transformation and Distribution Sector
- Energy Resources Sector

As mentioned earlier, the flexibility of LEAP enables us to examine only the demand sector and residential sub-sector within it. The tools of representing these data in LEAP are quite flexible and simple. In the process of creating a model for any energy sector the first step is to elaborate the structure of the system where the initial information about the system states is inputted. Afterwards a possible evolution scenario and different mitigation scenarios are modeled and compared. The structure of the Tbilisi residential sector is based on statistic from 2009, and has the following form:

There are 1.152 million residents in Tbilisi, with approximately 3.6 persons per household, in total 320,000 households in Tbilisi.

All Tbilisi dwellings are connected to the electric grid and use electricity for lighting and other purposes.

The average urban household annually consumes 1037.04 KWh for lighting.

Other devices such as VCRs, televisions, and refrigerators annually consume 772.19 KWh per household.

The annual energy intensity of air conditioners is 189.41 KWh per household.

8.3% of Tbilisi dwellers use electric appliances for heating, the remainder uses natural gas heaters.

The annual demand for useful energy for heating is 0.24 toe per dwelling. The efficiency of electric heaters is 100% and they consume 2787.19 KWh of electricity per household, for natural gas heaters, the efficiency is 87% and they consume 337.23 cubic meters of gas annually.

30% of Tbilisi dwellers use electric water heaters, the remainder use natural gas heaters.

The annual demand for useful energy for water heating is 0.92 toe. The efficiency of electric heaters is 95% and they consume 1121.44 KWh per household. For natural gas water heaters the efficiency is also 95%, and they consume 118.05 cubic meters of gas annually.

Tbilisi households use natural gas stoves for cooking. They consume 249.6 cubic meters of gas annually for cooking.

Reference Scenario:

The current accounts represent a “snapshot” (initial status) of the municipality prior to implementing any mitigation measures. It is very important to take into account the anticipated changes in the demand for and consumption of energy. The reference scenario shows possible trends of the development of the initial status in the case that there is no energy programmed implemented.

The reference scenario is usually called the “business as usual” (BAU) scenario, because it shows how the initial status would change in the case of no municipal energy program.

The demand drivers for energy demand and consumption in households are population growth, country GDP, and GDP per capita growths:

The population of Tbilisi will grow at an annual rate of 1.1%

Georgian GDP will grow at the following rates:

	2012	2015	2020
GDP Growth	4%	5%	5%

The Georgian population will grow at a rate of 0.5%

The energy demand for heating will grow with an elasticity of 0.3 to GDP per capita, and energy consumption will grow accordingly with no efficiency improvements

The energy demand for water heating will grow with an elasticity of 1 to GDP per capita, and energy consumption will grow accordingly with no efficiency improvements

The energy demand for lighting will grow with an elasticity of 0.4 to GDP per capita, and energy consumption will grow accordingly with 20% efficiency improvements

The energy demand for electric appliances will grow with an elasticity of 0.5 to GDP per capita, and energy consumption will grow accordingly with 10% efficiency improvements

The penetration of air conditioning systems will increase by 4% annually. The energy demand of household will grow with an elasticity of 1 to GDP per capita, and energy consumption will grow accordingly with no efficiency improvement

The energy demand for cooking will grow with an elasticity of 0.1 to GDP per capita, and energy consumption will grow accordingly with no efficiency improvements

Results – Baseline Inventory

In 2009 the fuel consumption in the households sector accounted for 2731 thousand MWh.

FINAL ENERGY CONSUMPTION (Thousand Megawatt-Hours) - 2009

	Electricity	Natural Gas	Total
Residential Buildings	798.04	1933.92	2731.96

In 2009 the emissions from the household sector accounted for 1314 thousand tonnes of CO₂ eq.

CO₂ EQUIVALENT EMISSIONS (Thousand Tonnes) - 2009

	Electricity	Natural Gas	Total
Residential Buildings	319.17	389.33	708.49

Results – Baseline Scenario

According to the reference scenario, in the future the energy consumption of the household sector in will increase for all fuels and reach 3515.52 GWh by 2020.

FINAL ENERGY CONSUMPTION (Thousand Megawatt-Hours) - 2020

	Electricity	Natural Gas	Total
Residential Buildings	1029.84	2485.67	3515.52

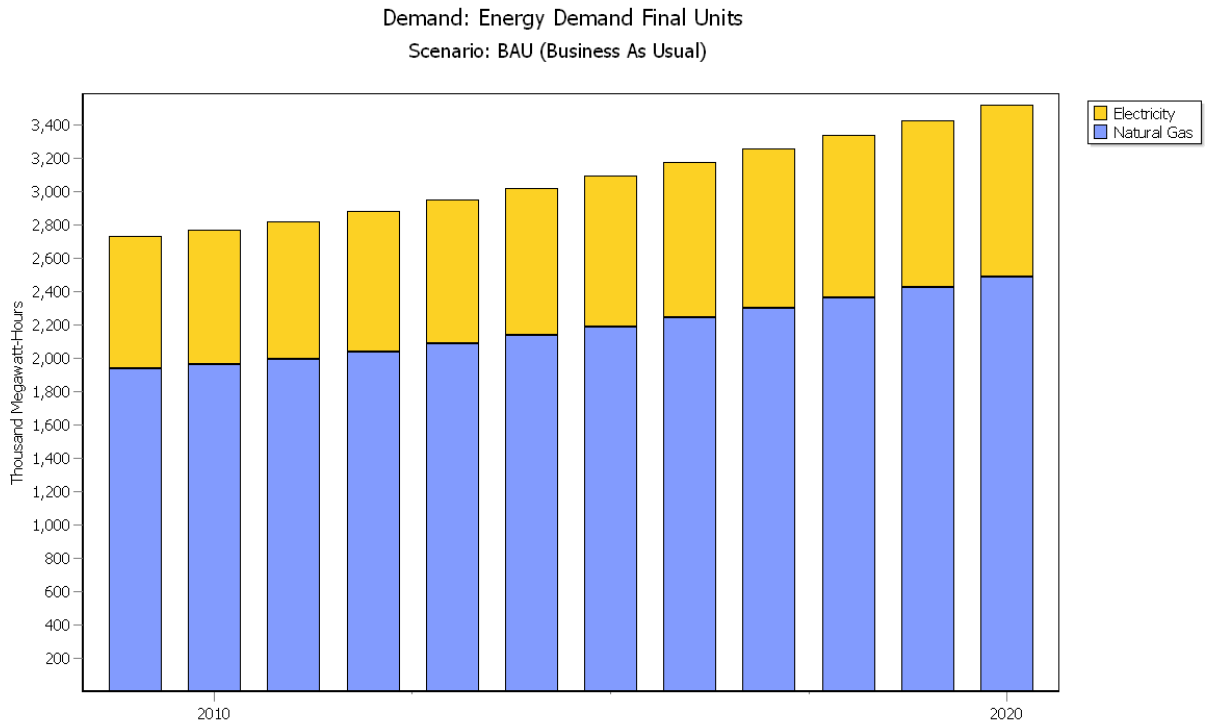

Fig.4.1 Reference scenario of energy consumption from the residential sector

The next figure shows the trends of emissions from the Tbilisi household energy sector according to the BAU scenario. It will reach 912.33 thousand tonnes of CO₂.

CO₂ EQUIVALENT EMISSIONS (Thousand Tonnes) - 2020

	Electricity	Natural gas	Total
Residential Buildings	411.88	500.45	912.33

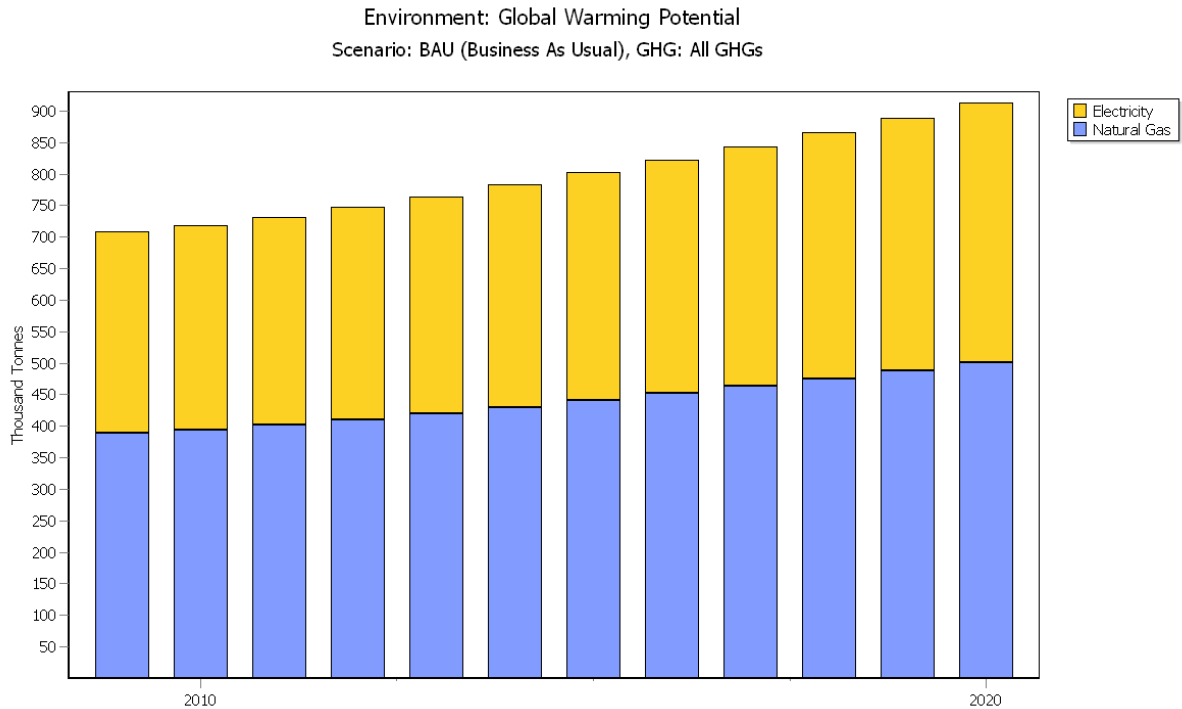

Fig.4.2 Trends of emissions from the residential sector by BAU scenario

2.4. Buildings Sector General Strategy for Reducing Greenhouse Gas Emissions in the City

The basic concept that is always considered with respect to the buildings sector is that buildings should be optimized with regard to energy consumption costs and the availability of supply. The Tbilisi city building stock represents a “Soviet approach”, manifesting itself in design and energy supply. In Soviet times energy was cheap and energy efficiency and greenhouse emissions trends weren’t “hot topics” in the world.

The result of the analysis of the buildings sector of Tbilisi indicates that there is a huge potential for the reduction of energy consumption. Correspondingly, this means that reducing the emissions levels of buildings should be a set goal for SEAP activities in Tbilisi.

The overall strategy for the buildings sector in Tbilisi is aimed at reaching a reduction of greenhouse gas emissions through a sustainable use of energy resources and a reduction in overall energy consumption.

The underlying assumptions that led to setting this goal are as follows:

Buildings were mainly built during the Soviet era with building envelope thermal properties that didn't consider enhanced energy efficiency. Thus they are characterized by huge heat losses in the winter. Heating systems were designed for a constant heat supply through district hydronic heating systems. Such systems not only ceased to function, but were physically dismantled in the following years. Also, these houses were not repaired or upgraded for decades, which led to further deterioration of the building envelope, especially windows. An insignificant number of these windows were replaced by modern metal-plastic ones. A majority of the building stock needs refurbishing or at least significant weatherization in order to reduce energy consumption, achieve emissions reduction targets, and provide comfortable conditions for the population. As buildings have a relatively long lifetime, refurbishments should take place every 30 to 40 years for residential buildings. For commercial buildings, these renovations may happen more often because the functions of commercial buildings change faster. With these major building renovations or refurbishments, high energy efficiency levels can be obtained. This measure is necessary because major parts of buildings as well as installations are worn-out and need to be replaced. An important factor that should be taken into consideration is that lifestyle choices and demands for comfort are constantly changing in a modern society.

A major part of newly built houses also do not meet the minimum standards of building envelope thermal properties. An additional factor is that there is no formally formulated and implemented government strategy aimed at the mitigation of these negative trends and/or the creation of an enabling environment for the population and business to improve thermal properties of buildings.

1. Action plan measure/measures should reflect upgrading/insulation

There is no governmental approach targeting the issue of heating systems. The population has to choose a heating system based on an understanding of what they can afford. Thus, since district hydronic heating systems don't exist, the shift has been made mostly towards natural gas heaters and electric heaters to a lesser extent because they are more expensive to use. Space hydronic heating (apartment) systems require high investments, which means that they aren't commonly used. The existing natural gas supply systems in buildings was designed as an internal, low pressure one and built without taking into consideration the possibility of applying natural gas to any other uses beyond cooking and occasionally heating water. Therefore, under the current conditions when the centralized heating and hot water supplies ceased to function, the gas lines could not cope with the sharply increased load caused by heating and hot water supply needs. As a result, there are noticeable fluctuations in the gas supply and the existing pressure in the

system does not allow the heating and hot water supply systems to work properly, leading to a decrease in appliance efficiency, incomplete combustion, and a corresponding increase in CO₂ emissions. In general the population (especially its poorest part) is not informed about these problems and acts as it sees fit in order to satisfy the needs of heating and hot water supply, which in general are highly inefficient and often hazardous approaches.

2. Action plan measure/measures should highlight the heating system's energy efficiency as well as safety issues.

Modern, energy efficient bulbs constitute an insignificant part of all bulbs currently used in Tbilisi. In general consumers (both the population and businesses) are mostly uninformed of the advantages of such appliances. Besides this, the one-time replacement of old bulbs with new ones is a rather expensive undertaking. At the same time the replacement of incandescent lighting bulbs with fluorescent ones has the largest energy efficiency increase and consumption reduction potential of all the available measures.

3. SEAP measures addressing the buildings sector should incorporate measures aimed at the replacement of incandescent bulbs with fluorescent ones.

The municipal buildings present a specific group of energy consumers that should be treated separately from others, since they have an extremely significant social value and are constantly in the center of the general public, political organizations, and non-governmental sector's attention. Thus, specific pilot projects underlying the issues of "low energy consumption buildings" should be designed to illustrate a municipal approach as well as the efficiency of its activities.

4. The Sustainable Energy Action Plan should include measures that address the pilot "low energy consumption buildings" projects for municipal buildings.

Energy consumption as well as CO₂ emissions in the buildings sector can be reduced through the utilization of local renewably energy potentials. Renewable energy resources available in Tbilisi provide an opportunity to utilize them.

5. SEAP measures should target the utilization of "renewable energy resources".

Implementation of the above measures should be carried out within the framework of SEAP's target and should be based on the following actions by the municipality:

- creating an enabling environment

- providing opportunities
- setting up examples
- generating citizen support
- directly engaging citizens in the actions
- generating support and engaging various parties into SEAP activities

2.4. Action plan in buildings sector

SECTORS & Fields of Action	KEY Actions/Measures per sectors/fields of action	Responsible Agency	Implementation Period [start & end time]	Estimated Costs per action/measur e (in GEL)	Expected Energy Savings per measure [MWh/a]	Expected Renewable Energy Production per measure [MWh/a]	Expected CO ₂ Reduction per measure [t/a] in 2020	CO ₂ Reduction Target per sector [t] in 2020
Buildings								183353
Municipal Buildings								
Action MB 1	Installation of space heating systems in municipal buildings	Economic Policy Agency, Tbilisi City Hall		1 780 000	1055	6305.3	1482.9	
MB 1.1	Heating systems with local boilers operating on natural gas		2012-2015	1 130 000	1055		209.6	
MB 1.2	Use of biowaste briquettes for local space heating in municipal buildings/pilot project		2014-2018	650 000		6305.3	1273.3	
Action MB 2	Installation of efficient lighting in municipal buildings	Economic Policy Agency, Tbilisi City Hall		41760	1147.5		447.9	

Sustainable Energy Action Plan – City of Tbilisi

MB 2.1	Lighting system with fluorescent bulbs		2012-2015	41760	1147.5		447.9	
Action MB 3	Refurbishment of municipal buildings	Economic Policy Agency, Tbilisi City Hall		1 925 293	3642.95		753.8	
MB 3.1	Insulation of building's exterior structure/ development of energy passport		2014-2020	1 744 000	3277		661.7	
MB 3.2	Low energy building/pilot project		2015-2016	181 293	365.95		92.1	
Action MB 4	Use of renewable energy sources for hot water supply purposes	Economic Policy Agency, Tbilisi City Hall		117000		189	37.8	
MB 4.1	Use of solar collectors in sports schools		2015-2020	65 000		105	21	
MB 4.2	Use of solar collectors in hospitals		2016-2020	52 000		84	16.8	
Action MB 5	Education/Information /Public Awareness/ Campaigns	Economic Policy Agency, Tbilisi City Hall	2012-2020	70125	1287		260	
Action MB 6	Establishment of energy management and monitoring program in municipal buildings	Economic Policy Agency, Tbilisi City Hall		500 000			1850	
MB 6.1	Controlling energy consumption, specifying behavior patterns							
MB 6.2	Development of municipal buildings energy database							
MB 6.3	Specifying energy efficiency indicators for state procurement							

	in tender documentation for carrying out rehabilitation							
Residential Buildings								
Action RB 1	Installation of central heating systems in residential buildings	Economic Policy Agency, Tbilisi City Hall		7 696 000		57200.7	11506.37	
RB 1.1	Use of geothermal water for heating and hot water supply/pilot project		2013-2015	6 896 000		50895.4	10280.87	
RB 1.2	Use of biowaste briquettes for central heating and pilot project		2015-2020	800 000		6305.3	1225.5	
Action RB 2	Installation of efficient lighting system	Economic Policy Agency, Tbilisi City Hall		1 000 000	29410		11730	
RB 2.1	Installation of fluorescent bulbs in common property areas of residential buildings		2012-2018	1.000. 000	29.410		11730	
Action RB 3	Refurbishment of residential buildings	Economic Policy Agency, Tbilisi City Hall		262829520	698381		141659.6	
RB 3.1	Weatherization of common property areas/ minimization of infiltration		2012-2018	31 749 600	109722		22161.6	
RB 3.2	Insulation of roofs		2014-2020	79137000	216270		44037	

RB 3.3	Insulation of residential building's exterior structure		2015-2020	150 000 000	367983		74330	
RB 3.4	Low energy house/pilot project		2014-2018	1 942 920	4397		1131	
Action RB 4	Use of renewable energy sources for hot water supply purposes	Economic Policy Agency, Tbilisi City Hall		650 000		1050	210	
RB 4.1	Installation of solar collectors for hot water supply purposes (pilot project)		2013-2016	650 000		1050	210	
Action RB 5	Education/Information Campaign	Economic Policy Agency, Tbilisi City Hall		60 000	90332		18247	
RB 5.1	Carrying out trainings in energy efficiency construction issues for different target groups (smart energy construction experts)							
RB 5.2	Mass-media and energy efficiency campaign							
Total					825255.5	64745	188185.4	

2.5. Description of Energy Efficiency Measures in the Buildings Sector for the Period 2011-2020

Action MB 1 - Installation of space heating systems in municipal buildings

MB 1.1 - Heating systems with local boilers operating on natural gas

Currently, the municipal building stock has been partly repaired and the central heating hydronic systems with local boilers have been installed in some of these buildings. Still, the remaining municipal buildings are without central heating systems with boilers. In these buildings, like kindergartens, “Karma”-style individual gas heaters or electric individual heaters are mostly installed. In some cases individual gas heaters are installed only in common rooms, like in kindergarten #107, located in the Gldani-Nadzaladevi district (Gldani’s 6th micro-district). In this kindergarten “Karma” gas heaters are installed only in the playrooms, and energy consumption doesn’t cover the baseline energy demand of the kindergarten building.

The municipality itself is planning to repair the remaining municipal buildings. Thus this measure is fully in compliance with municipal planning. It is important to note that by implementing this measure, safety standards in buildings (especially in kindergartens) will be improved.

This measure foresees the installation of central heating systems in municipal buildings where modern heating systems currently do not exist. It is recommended to install boilers with furnaces operating on solid fuel. This will provide an opportunity for the use of various fuels like natural gas with the possibility to switch over to biowaste pallets. It should be noted that replacing individual heaters with central heating systems using efficient boilers will improve the indoor conditions as well as contribute to the reduction of CO₂ emissions, since it is known that the system’s efficiency with a boiler is higher than the “Karma”-style individual heaters. The efficiency of “Karma” heater is reported to be 85-87% by producers. In our calculations we will use an efficiency of 85%, assuming that the energy efficiency of a heater is affected by fluctuations of gas pressure in the gas distribution network. Modern gas boilers have a higher energy efficiency rating, so in our calculations we use a 90% efficiency based on the same assumption regarding fluctuations in gas pressure during peak hours.

Without the application of any other measures, the savings specifically in heat consumption (per m²) during the heating season for a single (model) building with a central heating system and a

condensing boiler will constitute: 21kWh/m².⁴¹ For a single building the savings in delivered energy have been identified as 52,750 kWh/y. Considering that the caloric value of gas is about 33675 KJ/Nm³ or 9.36 kWh/Nm³ we can arrive at a natural gas savings of: 52750/9.36 =5636 m³. In monetary terms this would constitute: 5636x0.51=2874 GEL. The reduction of CO₂ emissions achieved by implementing this measure in one municipal building with a total heated area of 2495 m² is estimated as –10.48 t/year.

The total investment for a central heating system with a boiler for one building with a 2495 m² heated area is estimated at about 46,000 GEL.⁴² In the case of an individual “Karma”-style heater, the investment would constitute 45,000 GEL. The total investment and installation costs for central heating would constitute 56,500 GEL. In the case of “Karma” heaters, the investment and installation costs would be 51,000 GEL. The investment cost difference constitutes 5500 GEL between the two heating system options:

- a. with individual gas heaters
- b. with a central system and boiler

This measure should likely be implemented in those municipal buildings where individual gas heaters haven't yet been installed.

The economic calculations presented in the table below illustrate the profitability of this measure.

Measure	Investment Cost Difference	PB	IRR	NPVQ	CO ₂ Reductions
Central heating system (F=2495m ²)	5500 GEL	2.1	47%	1.87	10.48 t/year

PB – payback period; IRR – internal rate of return; NPVQ – net present value coefficient

It is expected that a modern central heating system with a condensing boiler will be installed in at least 20 buildings.

⁴¹ Assessment was performed with the use of the “Key Numbers” Software program

⁴² Reference data has been derived from the model kindergarten building geometry.

MB 1.2 - Use of biowaste briquettes for local space heating in the municipal buildings and pilot project

This measure stems from the previous one. Biowaste briquettes could be considered for heating purposes as a fuel instead of natural gas in municipal buildings. A pilot project should be launched in order to identify all aspects of this application. Biowaste briquettes are a carbon-free fuel that provides the opportunity for meeting the targeted 20% reduction of CO₂ by 2020.

The price of biowaste briquettes on the market is approximately 500 GEL/ton. This caloric value constitutes 160000 KJ/kg. This means that during the combustion process 1kg of biowaste briquettes will release 4.44 kWh of energy. Also, the received price of 1 kWh of energy will constitute 0.1126 GEL/kWh.

The price of 1000 m³ of natural gas varies for different consumer groups and for public buildings constitutes about 0.75 GEL/m³. This means that the price of 1000 m³ is 750 GEL, and the caloric value of natural gas constitutes 33675 KJ/Nm³. During the combustion process 1 m³ of natural gas releases 9.36 kWh of energy. Thus the price of 1 kWh of energy from natural gas will constitute 0.08 GEL/kWh.

With a comparison of prices it can be seen that biowaste briquettes are more expensive than natural gas.

Another aspect indicates that the total amount of energy needed for heating the model building covered by a natural gas energy carrier will constitute about 630.33 MWh/y.⁴³ or $630.33/9.36=67344\text{m}^3$ of natural gas.

As was already mentioned, biowaste briquettes are carbon-free, thus shifting this fuel will result in reductions of CO₂ emissions by $630.33 \times 0.202 = 127.33$ t/year (for one building with a total heated area $F=2495\text{m}^2$).

It is assumed that the pilot project results can be extended to at least ten municipal buildings, aiming at a fuel switch from natural gas to biowaste briquettes.

Action MB 2 - Installation of efficient lighting in municipal buildings

MB 2.1 - Lighting system with fluorescent bulbs

⁴³ In this the calculations used are from the same reference building data as in the previous measure.

The assessment of energy savings potential for this measure is based on the same reference building data that has been used for evaluating the previous municipal building measure.

The energy savings potential has been identified through an analysis performed for a lighting system with incandescent bulbs compared to a lighting system with fluorescent ones.

Assumptions used in the calculations are as follows:

- building heated area constitutes 2495 m²
- incandescent bulbs use 8 W/m² of energy
- fluorescent bulbs use 2 W/m² of energy
- bulbs in the building are switched on approximately 49 hours/week.

The energy consumption baseline for incandescent bulbs will constitute 50998 kWh/y, and for fluorescent bulbs the energy consumption constitutes 12748 kWh/y.⁴⁴

The savings for the model building constitutes -38250 kWh/y. In monetary terms this would be 38250x0.16=6120 GEL.

The investment cost for fluorescent bulbs will constitute 1392 GEL (6GEL per bulb).

The profitability calculation results for this measure are given in the table below. CO₂ emission reductions for this measure will constitute 14.93 t/year.

Measure	Investment	PB	IRR	NPVQ	CO ₂ Reductions
Lighting system with CFC (F=2495m ²)	1392 GEL	0.2	409%	6.34	14.93 t/year

It is expected that energy efficient bulbs will be installed in at least 30 municipal buildings.

Action MB 3 - Refurbishment of municipal buildings

MB 3.1 - Insulation of building's exterior structure and development of an energy passport

Since buildings have a long lifetime averaging 50 to 100 years or even more, major renovations and improvements should be performed during the lifetime of buildings. Refurbishments or

⁴⁴ Results are obtained from the "Key Number" Software Program

improvements are necessary because some parts of the buildings, like roofs and windows, need replacement.

It is known that the building and its heating system present one single unit. By upgrading the structure of the building the load of the heating system will be reduced.

This measure aims at assessing the insulation of the entire exterior structure of the building. In calculations R - value constitutes: for walls - $R=1.9 \text{ m}^2\text{C}/ \text{W}$, for double glazed windows - $R=2.5 \text{ m}^2\text{C}/ \text{W}$, and for roof $R=3.9 \text{ m}^2\text{C}/ \text{W}$.

Savings in energy consumption resulting from this measure have been obtained from the Energy Passport Software Program and constitute 327700 kWh/y. This means that the building will have the same comfortable indoor conditions, but the heating system consumption will be reduced by 327700 kWh/y. In the case of a natural gas energy carrier savings will constitute $327700/9.36=35010 \text{ m}^3$.

In monetary terms it will be $35010 \times 0.75=26257 \text{ GEL}$. The investment cost is estimated at 174,400 GEL.

The reductions in CO₂ emissions are estimated at 66.17 t/year.

To identify the economic profitability of this measure, economic calculations have been carried out using the ENSI Economy software program. The results of these calculations are given in the table below.

Measure	Investment	PB	IRR	NPVQ	CO ₂ Reductions
Insulation of structure of the building (F=2495m ²)	174 400 GEL	6.6	14%	0.24	66.17 t/year

Assumptions are associated with the understanding that starting from 2015 at least 10 municipal buildings would have upgraded thermal properties of the exterior surfaces. An energy passport with rating criterion will be developed for each of these ten buildings, with the purpose of illustrating the results of these measures to all stakeholders.

MB 3.2 - Low energy building and pilot project

The term “low energy building” is generally used to indicate buildings that have a higher energy performance than standard buildings, and thus will have a low energy consumption compared to a standard one.

The assumptions used for this measure incorporate three main energy efficiency dimensions identified for efficient buildings:

- high insulation of building exterior properties
- efficient modern central heating and domestic water supply system
- efficient lighting system

In carrying out an assessment of this measure an integrated approach has been used based on results derived from previous measures.

Integration of the abovementioned measures resulted in an energy savings identified from the energy budget balance of the software program as 365,950 MWh/y.

The reduction of CO₂ emissions will constitute 92.08 t/year.

The total investment will constitute 181,292 GEL and the savings has been identified as 34,800 GEL. The payback period for all measures will constitute 5.2 years.

Measure	Investment	PB	IRR	NPVQ	CO ₂ Reductions
Low energy building (F=2495m ²)	181292 GEL	5.2	-	-	92.08 t/year

Action MB 4 - Use of renewable energy sources for hot water supply purposes

MB 4.1 - Use of solar collectors in sports schools

Solar collectors transform solar radiation into heat and then transfer that heat to water that can be used for domestic hot water supply purposes. This measure foresees the application of solar vacuum collectors for the hot water supply in municipal buildings like sports schools, kindergartens, and hospitals.

Assuming that on average about 100 persons attend sports school, which need about 15 liters of water per person, we can derive the number 1525 liters/day. This will give us 549 m³ of water for which 20764 kWh/year is needed.

It is known that the amount of energy from solar radiation on the horizontal surface in Tbilisi is about 1200 kWh/m²/year. With a 90° angle orientation of the solar collector’s surface, the input from solar radiation can be increased by 25% and would constitute 1500 kWh/m²/year.

Assuming the efficiency of the solar collector is 70%, we can receive 1050 kWh/m²/year.

If we use solar vacuum collectors, assumed to be installed on the roof of the building, with a total surface of 20 m² we will arrive at 21000 kWh/year. The standard solar collector has a surface of 2 m² and costs 1300 GEL. In our case we would need 10 solar collectors, so the total investment will constitute 13,000 GEL.

The natural gas needed for the amount of energy defined as 21000 kWh/year constitutes: 21000/9.36 =2243.6m³. In monetary terms this will constitute 2243.6x 0.75=1683 GEL

The reduction of CO₂ emissions in the case of a transfer from natural gas to solar energy will constitute 4.2 t/year.

Measure	Investment	PB	IRR	NPVQ	CO ₂ reductions
Solar hot water supply (F=2495m ²)	13000 GEL	7.7	12%	0.13	4.2 t/year

It is assumed that the solar hot water supply systems will be installed in five sports schools.

MB 4.2 - Use of solar collectors in hospitals

The same calculation results are applied to hospitals as are described in the previous measure. Assumptions are associated with solar collectors applications in four hospitals.

Action RB 1 - Installation of a central heating system in residential buildings

RB 1.1 – The use of geothermal water for heating and hot water supply and pilot project

The capacity of production in the geothermal wells of Saburtalo constitutes 2400 m³/day. The water discharge would be 2400/100 t/h, or 27.78 kg/sec.

The heat load would constitute 27.78x20x4.19 = 2.32 MW, if the temperature difference constitutes 20° C. It is assumed that the temperature of the supplied water is 55° C and the temperature of the return water is 35° C. The annual energy consumption would constitute 2.32x24x365 = 20323 MWh/year. For the heating season the consumption would constitute

$2.32 \times 24 \times 146 = 8129.28$ MWh/year. This means that the amount of energy $20323 - 8129.28 = 12193.72$ MWh/year is available for hot water purposes.

By replacing the amount of energy identified as 20323 MWh/year that in another case had to be covered by natural gas emission reductions will constitute 4105.24 t/year. The natural gas savings will constitute 2171260 m³. In monetary terms this savings will constitute $2171260 \times 0.51 = 1,107,342.6$ GEL.

Reference data of the model residential building has been used for an assessment of the energy savings potential of this measure. The energy consumption for the whole heating season has been identified with the use of Energy Passport Software program.

The area of the residential building constitutes $F = 2510$ m². If the building thermal properties are not upgraded, the amount of consumed energy during one heating season will constitute 606.697 MWh/year.

Therefore about 13 buildings with the same thermal properties and with a total area of about $2510 \times 13 = 32630$ m² can receive heating from the direct use of geothermal water in the winter period.

The investment cost for the installation of domestic hot water (identified as 896000 GEL) was obtained from the scenario described in the UNDP/GEF project report. Under this scenario the metering, pipes, and valves needed for a proper water supply has been considered. The investment cost for heating systems in these buildings has been roughly estimated. The total investment constitutes 1,896,000 GEL.

The economic calculations aiming at the assessment of profitability for this measure are given in the table below.

Measure	Investment	PB	IRR	NPVQ	CO ₂ Reductions
Heating with Geothermal Water	1,896,000 GEL	1.8	56 %	2.42	4105.24 t/year

Other improvements can be reached by introducing advanced technologies like a heat pump for the further utilization of energy potential at the temperature difference $t = 35 - 30 = 5^\circ\text{C}$. This will give the additional potential identified as $27.78 \times 30 \times 4.19 = 3.49$ MW.

$3.49 \times 24 \times 365 = 30572.4$ MWh/year. This is amount of energy that can be saved by shifting from natural gas and will constitute a gas savings identified as 3266239 m^3 . In monetary terms this will be $3266239 \times 0.51 = 1,665,782$ GEL.

A reduction of emissions will constitute an additional 6175.63 t/year.

Measure	Investment	PB	IRR	NPVQ	CO ₂ Reductions
Geothermal water potential with the heat pump	5,000,000 GEL	3.0	19 %	0.23	6175.63 t/year

A pilot project should be carried out to identify the best technical and technological solutions for the utilization of geothermal water potential.

RB 1.2 - Use of biowaste briquettes for central heating and pilot project

This measure has been described in the Sub-Action MB 1.2. It is expected to extend the results of the pilot project launched for municipal buildings to residential ones. The assumptions are associated with an understanding that the pilot project launched for the residential sector within its framework should cover the installation of a central heating system with a boiler house at least for 10 residential buildings.

The consumption of natural gas identified for the reference building constitutes 606.697 MWh, which in the case of using natural gas will release 122.55 t/year of CO₂.

If switched to natural gas, indicated as $606.696/9.36 = 64818 \text{ m}^3$ of natural gas can be saved and will contribute to reductions of 122.55 t/year of CO₂/reference building. In monetary terms this savings will constitute $64818 \times 0.51 = 33057$ GEL.

Measure	Investment	PB	IRR	NPVQ	CO ₂ Reductions
Central heating with the biowaste briquettes	80,000 GEL	3.1	30%	0.95	122.55 t/year

Action RB 2 - Installation of efficient lighting systems

RB 2.1- Installation of fluorescent bulbs in common property areas of residential buildings

This measure assumes the replacement of incandescent bulbs with fluorescent ones. For example, we can consider the common property area of a reference 10-storey residential building with a stairwell constitutes $F=389\text{m}^2$.

The lighting level for incandescent bulbs in the common property areas is considered as $3.5\text{W}/\text{m}^2$ minimum, so we can derive the energy amount identified as 1.3615 kW . Assuming that the annual consumption for incandescent bulbs constitutes about 3921 kWh , their replacement with fluorescent ones will save 2941 kWh , or in monetary terms this will constitute $2941 \times 0.16 = 471\text{ GEL}$.

The total number of replaced 100 W incandescent bulbs will be 14 . The total investment is associated with the cost of investment and the installation costs and will constitute about 100 GEL . The CO_2 emissions from one building will constitute 1.173 t/year .

The results given in this example can be used for other buildings, assuming that with a replacement the annual savings in common properties will constitute $7.56\text{ kWh}/\text{m}^2$.

The forecast is based on the understanding that at least in common areas of residential buildings with an area $F=3,890,000\text{ m}^2$, incandescent bulbs will be replaced with fluorescent ones.

Measure	Investment	PB	IRR	NPVQ	CO ₂ Reductions
Lighting with efficient bulbs	100 GEL	0.2	435 %	6.78	1.173 t/year

Action RB 3 - Refurbishment of residential buildings

RB 3.1 - Weatherization of common property areas and minimization of infiltration

The assessment of this measure has been based on a 9-storey multi-flat 99-apartment residential building data designed by architect S. Kavlashvili. The building has five entrances. The common property area constitutes $F=1485\text{m}^2$. One wall of the common property area, $F=220\text{ m}^2$, is exposed to ambient air. It is assumed that to build it up and install metal plastic windows with the total amount $F=100\text{m}^2$ (one per floor). It is assumed that by weatherizing and minimizing the infiltration in the building about 91.435 MWh can be saved. This will result in a natural gas savings estimated as $91.435/9.36 = 9769\text{ m}^3$, as well as an emissions reduction identified as 18.469 t/year . In monetary terms this savings from natural gas will constitute $91.435 \times 0.51 = 46,632\text{ GEL}$.

The investment and installation costs are estimated at 26,458 GEL.

Measure	Investment	PB	IRR	NPVQ	CO ₂ Reductions
Weatherization of common property areas	26458 GEL	5.3	18%	0.55	18.469 t/year

It is expected that this measure can be extended to an area $F=640\,000\text{m}^2$ (1200 buildings).

RB 3.2 - Insulation of roofs

By upgrading roofs of residential buildings from a thermal resistance value $R=0.83\text{ m}^2\text{C}/\text{W}$ to $R=3.3\text{ m}^2\text{C}/\text{W}$ the energy savings will constitute 24.031 MWh.⁴⁵ This energy savings would result in a natural gas savings defined as 2567.425 m³. Accordingly, the CO₂ emissions reduction will constitute 4.854 t/year.

The investment and installation costs have been defined as 8,793 GEL.

Measure	Investment	PB	IRR	NPVQ	CO ₂ Reductions
Insulation of roof	8793 GEL	6.7	15%	0.35	4.854 t/year

RB 3.3 - Insulation of residential building's exterior structure

The full refurbishment of all exterior properties is assumed by this measure. The reference data for the residential building has been used for the assessment of this measure. The exterior wall area is $F = 2510\text{ m}^2$, the roof $F=316\text{ m}^2$, and the windows $F = 445\text{ m}^2$.

The total area of the building's structure is 3587 m². The total investment with the inclusion of installation costs constitutes about 150,000 GEL. It is assumed that the exterior properties will be upgraded to a thermal performance R – value level for walls - $R=1.9\text{ m}^2\text{C}/\text{W}$, for double glazed windows - $R=2.5\text{ m}^2\text{C}/\text{W}$, and for roofs - $R=3.9\text{ m}^2\text{C}/\text{W}$.

⁴⁵ Numbers are obtained from Software program with the reference building data

The baseline energy consumption in the case of existing situation constitutes 606.697 MWh, and after the refurbishment of all exterior properties the energy consumption will constitute 238.714 MWh. The energy savings are associated with 367.983 MWh. This will save 39314 m³ of natural gas, or in monetary terms we arrive at $39314 \times 0.51 = 20,050$ GEL.

The emission reductions will be 74.33 t/year.

The forecast is based on the assumption that at list 1000 buildings' structures with a total area of $F = 3587000$ m², that constitutes about 9.7% of the total residential sector area should be upgraded with the aim of enhancing their energy efficiency.

Measure	Investment	PB	IRR	NPVQ	CO ₂ Reductions
Residential building's structure refurbishment	150000 GEL	7.5	13%	0.17	74.33 t/year

RB 3.2 - Low energy house and pilot project

This measure has already been illustrated as an example for the municipal buildings (MB 3.2). It is estimated that the total amount of saved energy will constitute 439.7 MWh as well as a CO₂ emissions reduction of 113.1 in residential buildings.

It is expected that ten buildings will be fully upgraded considering their exterior properties as well as the application of efficient bulbs and the installation of a new heating system combined with a solar domestic hot water supply system.

Measure	Investment	PB	IRR	NPVQ	CO ₂ Reductions
Low energy building (F = 2495 m ²)	194292 GEL	5.3	-	-	113.1 t/year

Action RB 4 - Use of renewable energy sources for hot water supply purposes

RB 4.1 - Installation of solar collectors for hot water supply purposes (pilot project)

This measure has been described in relation with the municipal buildings (MB 4.1).

Accordingly, the general results are interpolated for residential buildings. A pilot project should

be launched in order to determine its optimal technical solutions, technology applications, and policy issues aiming at the administration of this service and money collection.

It is assumed that based on the results of the pilot project this measure could be extended to 50 residential buildings. This will offer the opportunity to utilize solar energy and increase the share of renewable energy use in Tbilisi.

Measure	Investment	PB	IRR	NPVQ	CO ₂ Reductions
Low energy building (F = 2495 m ²)	13000 GEL	5.2	-	-	92.08 t/year

3. Street Lighting Sector

3.1. Current Situation and Future Trends

Tbilisi at night is known as the city of lights - almost all streets, avenues, parks, historical buildings, and neighborhoods are illuminated, which makes the capital very attractive to locals as well as visitors. In 2006, the Tbilisi City Hall began work on a street lighting project called “Tbilisi – The City of Light”. All five regions, both banks of the Mtkvari, and the roads between blocks and buildings have been illuminated for this project.



Picture 7: Tbilisi at night

The table below shows that the number of public lighting points has gradually increased from 2004 to 2010, which implies more consumption of electricity by the capital:

Years	Number of Lighting Points (street lighting as well as decorative lighting points)	Used electricity (ml) Kw/hr
2004	17600	15, 8
2005	25700	23, 0
2006	47910	30, 0
2007	61160	35, 7
2008	83920	43, 5
2009	92560	46, 8
2010	108480	49, 8

In 2006 the Tbilisi municipality had energy costs due to the street lighting of 2.4 million GEL or 30 million kWh per year.⁴⁶ In addition to the illumination of the city, the Tbilisi City Hall launched a campaign to replace lighting with energy efficient bulbs. More than 60 percent of light bulbs have already been replaced with High Pressure Sodium Lamps (HPSL), Compact

⁴⁶ Tbilisi City Energy Efficiency Concept Paper, 2008

Luminescent Lamps (CLLs) and Metal Halide Lamps (MHL) which are 1.5-3 times more energy efficient than existing Mercury Lamps. It was estimated that expanding and improving the street lighting system would lead to increased consumption of electricity by 15-20 percent over the next 2-3 years. But still the conservation potential was estimated to be about 5 to 10 percent. There are a number of measures that would make street lighting even more energy efficient if they were implemented. As it was estimated in the Tbilisi City Energy Efficiency Concept Paper of 2008, the installation of LED (light-emitting diodes) traffic lights has the potential to bring significant energy savings. The low-energy bulbs also open the possibility of using solar panels instead of running an electrical line, which could be particularly effective in remote areas. The actions that are envisaged to bring significant energy efficiency in the street lighting sector within the SEAP are listed and described below.

3.2. Street Lighting Baseline Inventory and BAU Scenario Development

The Structure of the Street Lighting Sector (Current Accounts)

The information on public lighting sector is based on 2009 year, and is following:

- There are 92560 lighting points (Street lighting as well as decorative lighting points) in Tbilisi
- The electricity consumption in Tbilisi public lighting equals to 46800 MWh.
- The Grid Emission factor equals to 0.39995 tons of CO₂ eq per MWh.

Reference scenario:

Since most of the territory of Tbilisi is well lighted already, the increase of public lighting points will depend on the increase of city, which on its side depends on population growth. Therefore the main driver for this sector is population growth.

- The population of Tbilisi will grow at 1.1% annual rate.
- The number of lighting bulbs will grow with the same speed as population
- There will be no improvement in energy intensity of existing light bulbs.
- It is assumed that there will be no change in grid emission factor.

Results – Baseline Inventory

In 2009 the electricity consumption in street lighting sector accounted 46.8 thousand megawatt-hours.

	ELECTRICITY	sum
Public lighting	46.8	46.8

Table 2: FINAL ENERGY CONSUMPTION (Thousand Megawatt-Hours)

In 2009 the emissions from street lighting sector accounted 18.72 thousand tons of CO₂ eq.

	ELECTRICITY	sum
Public lighting	18.72	18.72

Table 3: CO2 EQUIVALENT EMISSIONS (Thousand Tons)

Results – Baseline Scenario

According to the reference scenario, the energy consumption of the public lighting sector in the future will increase for electricity and reach 52.78 thousand megawatt-hours in 2020.

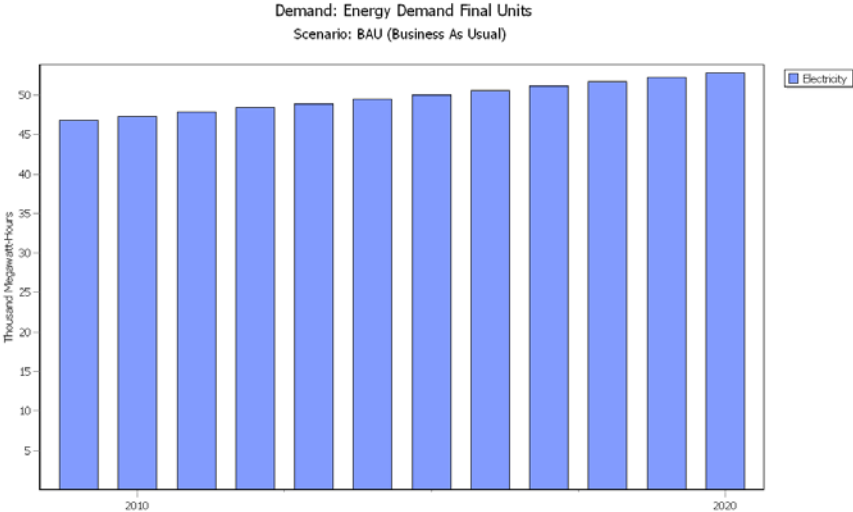

Figure 8: Energy consumption of the public lighting sector by 2020

The next figure shows the trends of emissions from the Tbilisi public lighting sector according to the BAU scenario. It will reach 21.11 thousand tones of CO₂ eq in 2020.

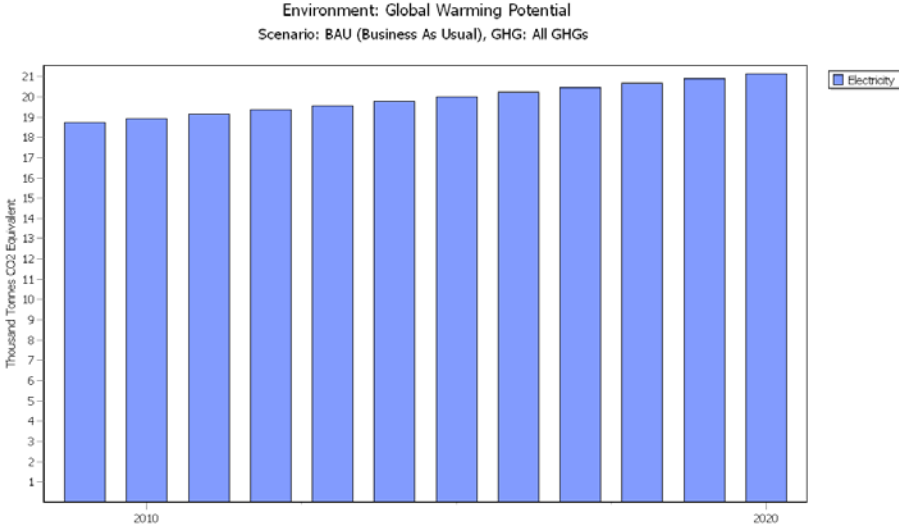

Figure 9: Trends of emissions from Tbilisi public lighting sector according to BAU scenario

The graphs below show the energy consumption by the street lighting sector in case of the SEAP action – Street Lighting Management Centre being implemented

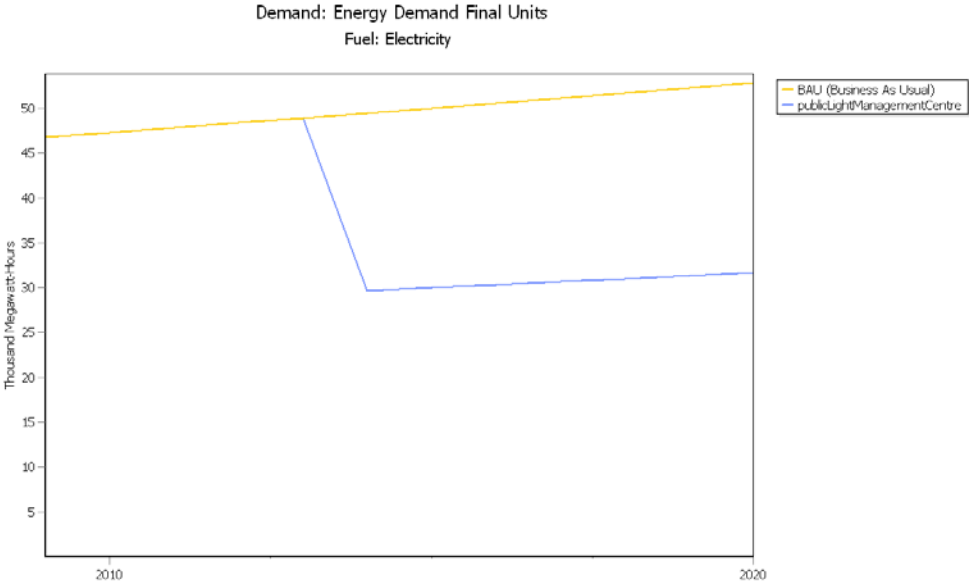

Figure 10: Energy consumption by street lighting sector in case SEAP action is implemented

3.3. Action Plan Table for Street Lighting Sector

SECTORS & fields of action	KEY actions/measures per sector/field of action	Responsible Agency	Implement action Period [start & end time]	Estimated costs per action/measure	Expected CO2 reduction per measure [thsnd/t] in 2020	CO2 reduction target per sector [t] in 2020
<i>Street Lighting</i>						21.11
Action S1	Intelligent Street Lighting Management Centre	Economic Policy Agency, Tbilisi City Hall	2012-2013	3 000 000 GEL	21.11	8.45
Total:					21.11	

3.4. Description of Actions

Action S1 – Intelligent Street Lighting Management Centre: The core element of intelligent street lighting system is stepless dimming of the lamp depending on the situation, for example according to the time of the day or intensity of car traffic on the highways if detectors are installed. The system will allow for the reduction of the intensity of the light output at night in the case of empty streets and roads and will increase the voltage when cars approach the area. The same mechanism could work in tunnels as well. Since lighting power is not directly related to the voltage, the following approach can be applied to regulate brightness of the light: to provide electricity with a full voltage for the first 5-10 minutes and after 10 minutes to reduce power to 195 watt. As a result, 25 percent less power would be used, while lighting would be diminished by only 7 percent. After midnight, power could be reduced to 140 watt, thus decreasing energy consumption by 63 percent. In addition, the system allows the stabilization of voltage and makes the street lighting network efficient and reliable. During the fluctuation of voltage, the pressure and temperature of bulbs will be maintained. The system can be managed by GSM mobile telephone network as well that makes it even more effective. The development and integration of an intelligent street lighting system will increase **the savings of electricity by 40%-60%**. The system was tested during one year and proved the results described above. The investment needed to implement the project is 3,000,000 GEL. Preliminary works will be conducted in 2012 and the project will be fully implemented in 2013.

Action S2 – LED Light for Street Lamps (alternative action): The action implies that in 2011-2013 a factory of the **light-emitting diodes (LED) light bulbs** will be constructed in Tbilisi. In 2014-2018 all street lighting lamps will be gradually replaced by the LED light bulbs. The total cost of the project is 76,000,000 GEL.

The light bulb replacement plan will be implemented according to the schedule presented below:

- In 2014 – 10,000 sodium light bulbs of 250 watt will be replaced by 64 watt LED lamps. As a result **7,551,600 kWh** of electricity will be saved.
- In 2015 – in total 20,041 sodium light bulbs (261 bulbs/400 watt; 5010 bulbs/250 watt; 14770 bulbs/150 watt) will be replaced by 64 watt and 48 watt LED lamps. As a result, **10,255,966 kWh** of electricity will be saved.
- In 2016 – 20,000 sodium light bulbs in total (3292 bulbs/150 watt; 16708 bulbs/70 watt) will be replaced with 48 watt and 24 watt LED lamps. As a result, **4,383,702 kWh** of electricity will be saved.
- In 2017 – 20,000 sodium light bulbs of 70 watt will be replaced with LED lamps of 24 watt. As a result, **3,735,200 kWh** of electricity will be saved.
- In 2018 – 15,000 sodium light bulbs of 70 watt will be replaced with LED lamps of 24 watt. As a result, **2,801,400 kWh** of electricity will be saved.

In total, as a result of project implementation **28,727,868 kWh** of electricity will be saved while the number of the street lamps will remain the same. As a result of this action 11.1 thousand tons of CO₂ equivalent emissions will be reduced.

4. Municipal Landfills

4.1. Current Situation and Future Trends

Since 2006-2007, the management of the municipal waste in Tbilisi has been improved considerably. In 2006, a Cleaning Municipal Department was created and the main functions of this Department have been defined as follows:

- Cleaning-up activities in the city
- Avoidance of waste generation and waste separation, recycle, and reuse
- Waste collection, treatment process, and its disposal
- Landfill management
- Elaboration rules for the regulation of waste management and cleaning
- Control the fulfillment of rules stated by the legislation in the field of waste management and cleaning

It should be mentioned that there is no special law on waste management that would regulate the sector on a national level. The following main legal acts are referred to and applied for regulation: the Georgian Law on Environmental Protection (1997) and the Georgian Law on Healthcare (1997). On a local level, according to the Georgian Organic Law on Local Self-Government (2006), the planning and implementation of collection and disposal of household wastes is the responsibility of local-government entities. However, legislation does not require municipalities to develop municipal waste management plans or clarify the legal status of these plans if they are developed.

The reform of the municipal cleaning sector of Tbilisi that started in 2006 became exemplary – new waste collecting vehicles were purchased, special waste collection bins were introduced and circulated throughout the city, incentives and restrictions were created to encourage the collection of waste more efficiently and keep the city as clean as possible. In the budget of the Council of Tbilisi for 2011, 50,823,300 GEL was allocated for cleaning activities in the city, including the closure/conservation of old landfills and maintenance of a new one.⁴⁷

Tbilisi city generates on average 1.3 million m³ waste every year.⁴⁸ Approximately 3,000 m³ of waste is collected and carried into the landfill sites every day.

⁴⁷ http://www.sakrebulo.ge/index.php?lang_id=GEO&sec_id=6&lang_id=ENG
http://www.sakrebulo.ge/index.php?lang_id=GEO&sec_id=6&lang_id=ENG

⁴⁸ Tbilisi City Hall Energy Efficiency Concept Paper, 2008

Years	Population (thousands)	Municipal Solid Waste(MSW), total in the city (in tons)
2001	1.088500	251.8688
2002	1.081700	276.3938
2003	1.079100	227.902
2004	1.078200	253.2724
2005	1.079700	232.85
2006	1.103300	274.003
2007	1.101100	292.0813
2008	1.136600	333.662
2009	1.136600	346.3558
2010	1.152500	353.1642

Table 4: Amount of municipal solid waste dumped on Tbilisi landfills, 2001-2010. Source: Tbilisi City Hall

The Tbilisi municipal waste consists of organic waste, paper and cardboard, plastic, glass, metal, fabrics, leather, and other waste (mineral waste, ash, street waste, dust and other unidentified waste). According to research conducted in 2003⁴⁹, the share of types of municipal waste looks as follows:

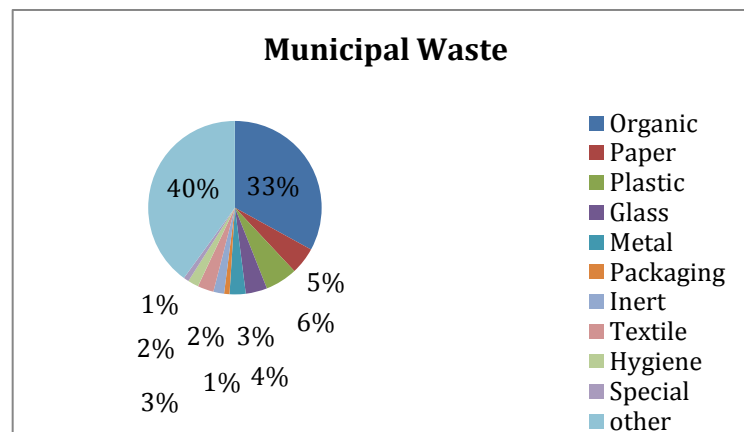

Figure 9: Composition of municipal waste, 2003 (weight - %)

⁴⁹ Tbilisi Municipal Waste Management Concept Paper, GTZ, 2006

Before 2010 Tbilisi was served by four different official landfills owned by the Tbilisi Municipality, including **Gldani** (Gldani 1, Gldani 2), **Lilo**, and **Iagluja**.

Closed Landfills: Gldani 1 and Gldani 2 started service in 1972 and were closed in 2010. The site covered 8 ha with more than 5.45 million tons of waste. The thickness of layers of the waste was a minimum of 8 meters and a maximum of 20 metres. The Gldani landfill served 52% of the Tbilisi population. The **Iagluja landfill** had a territory of 5 ha and was located approximately 25 km southeast of the centre of Tbilisi and operated from 1985 till 2010. The site served 48% of the population and accumulated more than 2.8 million tons of waste with layers 3 to 20 meters thick. The **Lilo landfill** functioned from 1989 till 2004 and covered 5 ha of territory. The thickness of layers of more than 1.8 million tons of waste deposited on the site was from 3 to 5 metres. In the table below further details are presented:

Landfill	Opening date of Landfill	Closing date of landfill	Population percentage served	Number of waste collection vehicles/daily	Load capacity of vehicles	Landfill management type	From which year do data exist?
Gldani-1	1972	2004	51.8		7m3	Covering with soil	2001
Gldani-2	2004	2010	60.8		40-12 m3	Covering with soil	2004
Lilo	1989	2004	48.2		7 m3	Covering with soil	2001
Iagluja	1985	2010	39.2		40-7 m3	Covering with soil	2004
Norio	2011	-	100	7-8 ths/t	40-7 m3	Covering with soil	2011

None of these landfill sites were protected properly – they were not fenced in and had open access for scavengers and cattle, thus creating a great risk of disseminating various diseases. A number of serious environmental problems were directly related to the operation of the landfills – none of them had groundwater protection or a leachate collection/treatment system, which caused serious air, groundwater, and water pollution.⁵⁰ Landfill gas (LFG) from the landfill sites was not collected either, therefore it was released into the atmosphere unchecked, which when emitted in low concentrations was a source of odor and when emitted in high concentrations was a potential cause of explosion or ignition. Moreover, since the main constituent of LFG is

⁵⁰ Draft of National Environmental Action Plan, 2011

methane, which has a global warming potential, the landfill sites had a negative impact on the global environment.



Picture 8: Gldani 2 and Iag1uja landfills, 2006

New Landfill: In March 2010, construction of a new landfill was launched near the Norio village in the region of Gardabani. The total area of the landfill is 83 ha and consists of 4 main sections. In November 2010, only the first section of the landfill (8 ha) went into service with a capacity for deposition of 30.000 tons on average of daily waste and serving 100% of the population. The service lifetime is 30-40 years and the possible waste layers thickness is 20-25 meters.



Picture 9: Norio Landfill, 2011

The site has fenced protection with restricted entrance for strangers and cattle. The waste vehicles are weighed at a weighbridge on arrival using the **RFID** system. Modern technologies are used to deposit and compact the waste into two-meter layers that are covered by a clay ground of 50 cm. The landfill is provided with a wastewater drainage/treatment system and methane collectors that prevent contamination of groundwater and/or aquifers by leakage and methane flaring. The plan is to introduce modern technologies for waste separation that will decrease the volume of waste to be deposited on the landfill and increase the share of recycled materials.

4.2. Baseline Emissions Inventory for Municipal Landfills

Description of the Problem

The commitment to reduce the GHG emissions from the city requires a preliminary assessment of these emissions for the current year and their development/projections in case special measures for emission reduction, envisaged by the Project, are implemented. The baseline presents the scenario of development without the project implementation.

Method and Assumptions

Calculation of the baseline scenario for GHG emissions implies the assessment of the emissions for the initial and the final years (2009 and 2020 accordingly) and the assumption that the emissions will follow the logic of population growth, without major breakouts in economical and/or political course.

The GHG emissions from the waste sector comprise those from

- a) municipal solid waste disposal sites
- b) wastewater
- c) waste incineration process

Only two sources of GHG emissions are calculated here according to IPCC methodology, adopted for GHG inventories compiled by all Parties to the UNFCCC.

GHG Emissions from Solid Waste Disposal Sites (SWDS)

There are 3 GHGs produced from landfills: methane (CH₄), carbon dioxide (CO₂) and non-methane volatile organic compounds (NMVOC). The most important greenhouse gas from solid waste disposal sites is methane (CH₄). CO₂ produced from organic material in the landfills is not considered as net-CO₂ emissions according to IPCC methodology. There are no methodologies for calculating CO₂ and NMVOCs.

CH₄ Emissions from SWDS

The calculation of methane emissions from Tbilisi-city landfills has been performed using the *IPCC Waste Model* implying the First Order Decay (FOD) method, considered as a high-tier method, adopted by the IPCC for key-sources of methane. The FOD method implies that a) methane is not produced from the dumped waste immediately but gradually, from decomposing masses of waste, during a *period of decomposition*, and b) the decomposition and consequent production of methane is following an exponential function. This period of decomposition is a parameter selected by the user (GHG inventory compiler) according to country-specific conditions and composition of the landfills.

Due to the exponential character of decomposition, the FOD method is considered to be one of the most complex in GHGs inventory and a simple spreadsheet model called *IPCC waste model* has been elaborated to facilitate the calculations. The model contains default values for parameters that are indicative, allowing a user to substitute them with country-specific data where possible. We input all the country-specific values that could be obtained for this model.

Description of the Parameters and Assumptions Made

To select the values for the parameters that the Model requires, we relied on the results of implemented projects and researches in Georgia, namely, the Georgian National GHG Inventory (2008), State of Environment (2010), National Environmental Action Plan, NEAP-2 (2010), Tbilisi Waste Management Concept (2007), Inventory of Waste on the Territory of Georgia (2007), “Landfill Gas Capture and Power Generation Project in Tbilisi Ver002, 05/01/2007(CDM PDD), 2006 IPCC GLs, as well as the default data included in the Model. Some activity data was taken from official websites and the Tbilisi Municipality. The values, the reasons for their selection, and the assumptions made are presented in the table below:

#	Parameter	Value	Justification and assumptions
1	Region	Eastern Europe	----
2	Climate	Wet temperate	This parameter refers to the climate at the site of the landfill – subject to assessment. It relates with the fact that the wet climate contributes to more methane production. The choice of climate pattern determines later k parameter characterizing methane production rate from degradable matter. Tbilisi’s climate is considered ‘hot dry’, but our choice for ‘Wet temperate’ results from the consideration of the conditions of Tbilisi landfills (till 2011) – without drainage that causes wet conditions for the waste disposed there. The choice for ‘Hot dry’ would not reflect the actual conditions.
3	Delay time (months)	6	Default from the model using IPCC default values
4	Fraction of methane (F) in generated gas	0,527	Country-specific, calculated (Georgia’s GHG Inventory, 2008, p. 119)
5	Methane Correction Factor (MCF)	0.4 (for 1961-1971) until the first managed landfill was open; since 1972 MCF=1	Until the first managed landfill was open, the municipal solid waste was considered to have been disposed of in different sites, in shallow dumps, the default MCF value has been 0.4.

			For managed landfills the default value is 1, and this value is used for the time series since 1972, when the first managed landfill was open.
6	Waste composition	Food, garden, paper, wood and straw, textile, disposable nappies, plastic and other inert waste. Sewage sludge is not disposed of in municipal landfills.	IPCC Waste Model default selection. The results of researches* have been used, with further re-classification – the allocation of each portion to the default categories. The researches provide different composition/distribution. After inserting them in the calculation, we have analyzed the following results: they appeared to be too low compared with the GHG inventory figures. Suspecting that the class 'Other waste', excluded from calculations by the model, was shown to be too large without sufficient details, we decided to distribute this portion among other categories and come closer to the Inventory's figures. The result appeared comparable to the Inventory estimates.
7	Waste composition (percentage)	Food, garden, paper, wood and straw, textile, disposable nappies, plastic and other inert. -39%, 4%, 34%, 4%, 3%, 2%, 14%.	Country-specific, based on the results of the researches*, ** Note: The composition requires some adjustment using additional data and further expert judgment, to reflect recent conditions.
8	DOC (degradable organic carbon)	For each waste category – country-specific (see the Table 1 below)	Mainly taken from Georgia's GHG inventory**(Table 6.9,p.118)
9	DOCf (fraction of DOC dissimilated)	0.517 , calculated value	Weighted average (0.517) value is calculated automatically by the model from country-specific values and the percentages for each waste category, inserted into the model: Food waste 0.7 Garden 0.26 (average from grass, leaves and branches) Paper 0.48 Wood and straw 0.36 Textiles 0.55 Disposable nappies 0.5 ⁵¹ (see Georgia's NIR, Tables 6.10, 6.11 and 6,12, pp. 118-119).

10	Oxidation Factor (OX)	0.1	The value is chosen issuing from the suggestions of 2006 IPCC Guidelines for GHG inventories – 0.1 value is recommended to be used for the landfills where the covering material is soil (this is Georgia’s case)
11	K methane generation rate	Different for different categories (see the Table 2 below).	Default values are suggested in the model (model uses IPCC default values) according to the chosen climate pattern (wet temperate). The model allows different lifetimes for different categories of waste
12	Methane recovery [®]	0	In Georgia there is no methane recovered yet.

Table 5: *Tbilisi waste management concept (2007); **Georgian National GHG Inventory (2008)

The tables presented below show the values of the parameters of DOC and k according to waste composition:

DOC (Degradable organic carbon) (weight fraction, wet basis)	Range	Default	Country specific value
Food waste	0.08-0.20	0,15	0,137
Garden	0.18-0.22	0,2	0,247
Paper	0.36-0.45	0,4	0,402
Wood and straw	0.39-0.46	0,43	0,393
Textiles	0.20-0.40	0,24	0,495
Disposable nappies	0.18-0.32	0,24	0,24

Table 6: DOC values for waste categories (fragment of the Model)

Methane generation rate constant (k) (years ⁻¹)	Range	Default	
Food waste	0.1–0.2	0,185	0,185
Garden	0.06–0.1	0,1	0,1
Paper	0.05–0.07	0,06	0,06
Wood and straw	0.02–0.04	0,03	0,03
Textiles	0.05–0.07	0,06	0,06
Disposable nappies	0.06–0.1	0,1	0,1

* IPCC waste model default value

Table 7: Methane Generation Rate for waste categories (fragment of the model)

Activity Data

The activity data includes the population allocated to the landfills, municipal solid waste (MSW) generated, and the share of the MSW dumped in the landfills.

The population of the city of Tbilisi has been taken from the official website of the Municipality (for years 2000-2010). Till 2000, the number has been used the same as in the National GHG Inventory of Georgia (2008).

In the model, the parameter ‘MSW generated per capita per year’ is considered and a default value is given. In our case we had the real values of weighted MSW (total) per year for the years since 2000, and we used them together with the population numbers (since 2000), to calculate MSW per capita, not using the default value for 2001-2010:

Years	Population (in thousands)	Municipal Solid Waste(MSW), total in the city (in tons)
2001	1.088500	251.8688
2002	1.081700	276.3938
2003	1.079100	227.902
2004	1.078200	253.2724
2005	1.079700	232.85
2006	1.103300	274.003
2007	1.101100	292.0813
2008	1.136600	333.662
2009	1.136600	346.3558
2010	1.152500	353.1642

Having consulted with the city municipality we assumed that all the MSW generated is taken and dumped in the landfills. So the percentage of MSW disposed of (parameter ‘% to SWDS’) is set at 100%.

Calculations

Provided with all the data about the municipal landfills (life-time, MSW portions, and population percentage allocated), it was possible to make calculations for each MSW stream and then sum up. But taking into consideration the requirement of the IPCC that closed landfills should be included in the calculations, we decided to make the calculations of the total emissions from all municipal landfills throughout all the years of their lifetimes together, as if we had one big landfill instead of two to three different ones. This assumption is justified by the evidence of getting identical results in both cases. The FOD method implies that each portion of disposed waste degrades according to the year of its disposal and the methane generation rate

(parameter k) chosen, it is not that important to know where exactly it is disposed. The only differentiation between the landfills is made according to their level of management: till 1972 the landfills are considered as shallow and unmanaged and since 1961 – managed, with corresponding MCF values (0.4 and 1).

The calculations begin from 1961, according to the assumption that nearly 50 years (till 2011) for calculations, recommended in IPCC guidelines, is provided. Methane emissions are estimated for three climatic regimes: wet temperate, dry temperate and dry tropical.

Results

Methane emission estimation, calculated for the year 2009 is 20.04 Gg CH₄, which is 420.84 Gg CO₂eq (for a ‘wet temperate’ climate, which was taken for the case of Tbilisi – see the justification above, in Table 2). The results for ‘dry temperate’ and ‘dry tropical’ cases are 17.73 Gg CH₄ (372.33 Gg CO₂) and 18.70 Gg CH₄ (392.7 Gg CO₂) respectively. We can see how much wet conditions affect methane generation. The most conservative assumption (dry temperate) has been used in calculations.

Projections

Since 2011 a new landfill has been operating, taking all the MSW from the city of Tbilisi. Projections have also been made in the same sheet together with past data, based on the assumption described above. Projections were made for the year 2020, according to population growth. The municipal population growth has been taken as 1.1% (www.geostat.ge), as the mean value for the last ten years of growth. Under this assumption the emission of methane from the municipal landfills is 22.4 Gg CH₄ or 470.4 Gg CO₂-eq(wet temperate climate), the same 20.19 Gg CH₄ (423.99 Gg CO₂) and 21.09 Gg CH₄ (442.89Gg CO₂) for dry temperate and dry tropical climate respectively.

Baseline Emission

The results for all three landfills together are presented in the graph below. The curve can serve as the baseline scenario from the city solid waste disposal sites.

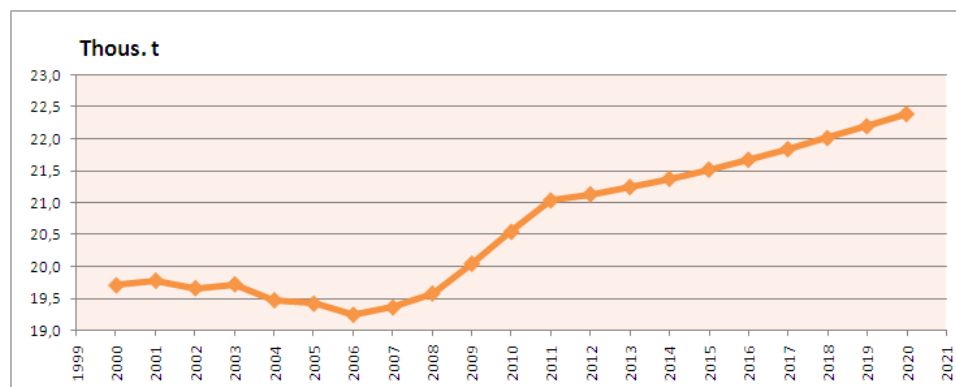

Figure 10: Baseline CH₄ emissions from the city solid waste disposal sites

The discrepancies from the emission estimates shown in the National GHG Inventory of Georgia (2007) can be explained by the different values chosen for composition, k and some other parameters, and assumptions made. The resulting figures of the calculations are less than those of the National Inventory, reflecting the fact that the assumptions made have been conservative. Further adjustments for disposed waste composition and/or k parameters should be done in the relevant projects’ feasibility study.

The graphs show the BAU scenarios separately for each landfill site where the mitigation measures are offered. Such separation is necessary for planning and assessment of methane reduction from each site:

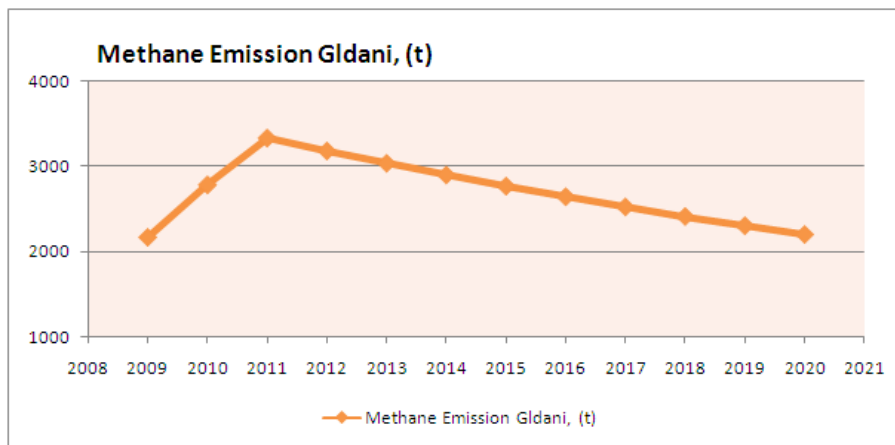

Figure 11: CH₄ emissions from Gldani landfill

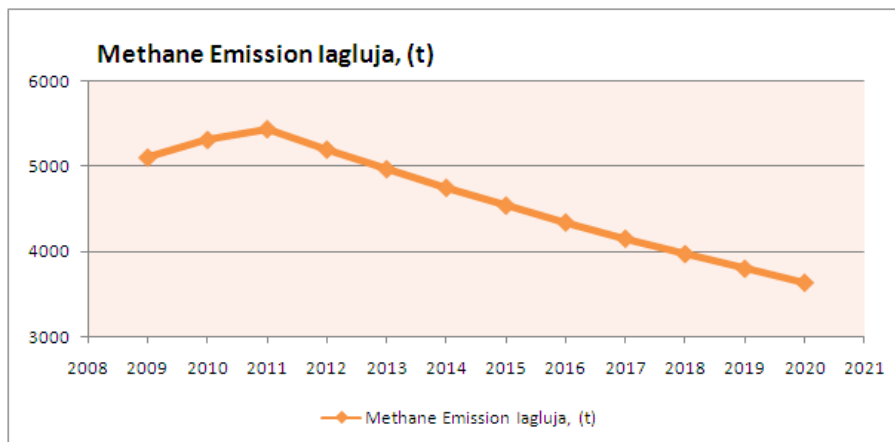

Figure 12: CH₄ emissions from Iagluja Landfill

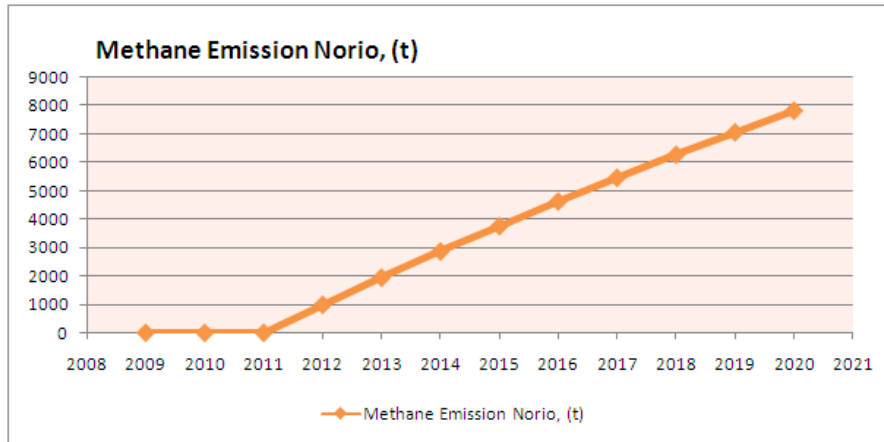

Figure 13: CH₄ emissions from Norio Landfill

4.3. Action Plan Table for Municipal Landfills

SECTORS & fields of action	KEY actions/measures per sector/field of action	Responsible Agency	Implementation Period [start & end time]	Estimated costs per action/measure	Expected CO2 reduction per measure [thsd/t] in 2020	CO2 reduction target per sector [t] in 2020
<i>Municipal Landfills</i>						249.111
Action L1:	Landfill Gas (LFG) Collection and Flare from Closed Landfill Sites (Gldani 2 and Iagluja)	Economic Policy Agency, Tbilisi City Hall	2012-2020	5,199,308 USD (Construction) 72,497 USD/Year (Operation)	106,58	1 141 911.7
L1.1	Construction and operation of LFG flaring system at Gladni 2			3,772,478 USD (Construction) 27,711 USD/Year (Operation)	40.33	437 512.1
L1.2	Construction and operation of LFG flaring system at Iagluja			1,426,830 USD (Construction) 24,786 USD/Year (Operation)	66.25	714 399.6
Action L2:	Landfill Gas (LFG) Flare from New Landfill Site (Norio Landfill)	Economic Policy Agency, Tbilisi City Hall	2012-2015	12 mil EURO	142.53	600 425
L2.1	Construction and operation of LFG flaring system at Norio				142.532.5	
Total					249. 112	

1. These calculations have been made based on the consideration that the measures will begin giving results from 2012.
2. For recovery the consideration was made that all the methane generated will be recovered.
3. The logic for calculation of emission reductions for flaring activities was the formula: ER (in t CO₂e) = CH₄ emission generated x 21 – CH₄ emission generated x 44/16 (CO₂ after flaring)
4. All the calculations are based on the conservative assumption of a dry temperate climate.

4.4. Description of Actions

The new municipal landfill for the city of Tbilisi (Norio) that began operations in January 2011 has equipment installed for the recovery of methane that will be generated in the depth of the dumped waste with years. The methane producing capacity from this landfill can be identified from the estimates of the emissions for every year, calculated using the IPCC waste model (see the baseline emissions estimates). In general, all the methane produced in the landfill can be recovered and used for energy purposes. It is worth mentioning that the baseline emissions calculated refers to all the landfills of Tbilisi-city. Nowadays all other landfills except the new one, Norio, are closed. Methane continues to be generated from these sites, and it is included in the baseline emissions calculation. But methane recovery is reasonable to carry out in the Norio landfill since there is equipment considered for this measure and the costs would be less. In the other, closed landfills a methane flare method is more appropriate, while on the Norio landfill first a methane-recovery project can be implemented in Georgia. However, some time (6 months is the adopted delay) is required before the gas will begin to generate. Other conditions (depth, management details, composition – possibility of selection/recycling) should be considered to calculate the amount of gas to be recovered, but it will be a constantly increasing quantity, exceeding 10 thousand tons CH₄ by 2020, according to the baseline estimations.

Box 1: Methane Flare/Recovery from Tbilisi Landfills

Actions L1 - Landfill Gas (LFG) Flaring from Closed Landfill Sites (Gldani 2 and Iagluja)

L1.1 - Construction and Operation of LFG Collection and Flare System at Gldani 2

The LFG collection system is composed of vertical collection holes, gas collection pipes, an airtight sheet, gasholders, measuring instruments, and blowers. The Flare system of this project is composed of an enclosed flare facility with 0.995 flare efficiency.

L1.2 - Construction and Operation of LFG Collection and Flare System at Iagluja The LFG collection system is composed of vertical collection holes, gas collection pipes, an airtight sheet, gasholders, measuring instruments, and blowers. The Flare system of this project is composed of an enclosed flare facility with 0.995 flare efficiency.

Action L2 - Landfill Gas (LFG) Flare from New Landfill Site (Norio Landfill)

L 2.1 – Construction of LFG Flaring System at Norio: The landfill is equipped with a landfill gas collecting system (pipes) and a collector pipe. The additional equipment will include methane-tanks, gas-holders, measuring devices, and a flare for the remaining gas.

L3- Landfill Gas (LFG) Recovery from the New Landfill Site (Norio Landfill)

L3.1 - Construction and Operation of LFG Recovery System at Norio Landfill: The landfill is equipped with an LFG collecting system (pipes) and a collector pipe. The system should entail ways for the use of the recovered gas (inner use, consumption for electricity and/or heat, use in

transport, etc), and additional equipment needed depending on the final use of the recovered gas (methane-tanks, gas-holders, measuring devices, a flare for the remaining gas, etc). The operation of the system implies checking of the facilities/devices and insurances of the system's proper functioning to the extent of its designed capacity.

5. Waste Water Treatment

5.1. Current Situation and Future Trends

At the national level, the Government of Georgia has articulated its reform agenda in its Water Supply and Waste Water Sector Development Policy, developed in 2009. There is a clear emphasis on infrastructure and service quality improvement, cost recovery, financial sustainability of regional water companies, and operational efficiencies, demand management through reduced water losses, service access to the poor and vulnerable, a legal and regulatory framework, and sector management through modern management systems—management information systems and geographical information systems.⁵²

On the local level, Chapter IX of the Strategic Plan of Tbilisi highlights the priorities within the sector of infrastructure, namely the water supply system of the city (Article 11) and the sewage system/waste water treatment (article 12). The latter envisages the improvement of the city sewage system, the construction of additional collector lines and the upgrade of an active Tbilisi-Rustavi regional waste water treatment plant (**Gardabani Waste Water Treatment Plant (WTP)**).

As for the current situation, “Georgian Water and Power” (GWP) is a private company that is responsible for delivering drinking water to Tbilisi and its neighborhoods and providing wastewater services to the capital. The company serves about 400,000 customers throughout the city, out of which about 2,000 are budget organizations, 15,000 are commercial objects, and the rest of them are residential customers.⁵³ At present, the total length of the Tbilisi drainage system is 1600 km with a diameter of 150- 1200 mm. The wastewater runs through the sewer to the Gardabani Treatment Plant.

The Gardabani WTP was constructed in 1986 as a mechanical-biological treatment plant with a capacity of 1.0 million cubic meters/day.⁵⁴ The design of the Plant implies a 3-step treatment process:

- rough mechanical and primary settlement
- aerobic/biological treatment
- secondary settlement

However, at present it performs only rough mechanical and mechanical cleaning of the discharged water. A complete rehabilitation and modernization of the WT plant is needed to ensure full biological treatment, including the reduction of its nitrogen and phosphorus content.

⁵² Asian Development Bank. Georgia: Developing an Urban Water Supply and Sanitation Sector Strategy and Regulatory Framework for Georgia, 2010

⁵³ <http://www.georgianwater.com>

⁵⁴ <http://www.georgianwater.com>

Actual Functioning Scheme of the Plant

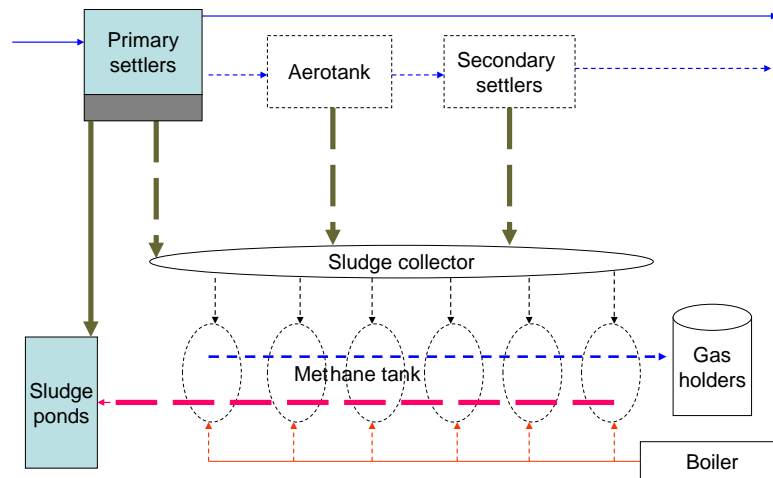

Figure 14: Functioning Scheme of Gardabani WTP

The plant receives about 210-225 mln m³/year (2005) of wastewater, consisting of municipal (about 97%) and industrial (from the Azoti chemical plant) influents. Six cylindrical methane tanks , which already physically exist though they have never functioned, are made of steel and concrete. The sludge is stored in open ponds, filled one after another, and the ponds have a slope for drainage purposes. As it was estimated in the project proposed under the Clean Development Mechanism (CDM) in the designed conditions, 13.3 t of CH₄ can be produced per day. The emission reduction potential was estimated to be 74,380 t CO₂ eq/a.⁵⁵

⁵⁵ Gardabani Wastewater Treatment Plant Rehabilitation Project. Medea Inashvili. Conference of Project EuropeAid/11523/C/SV/Multi-Lot No.2 Technical Assistance to Armenia, Azerbaijan, Georgia and Moldova With Respect of their Global Climate Change Commitments Batumi, Georgia, 1-2 June 2006

Proposed Project Activity – Methane Capture and Electricity Generation for Self-Use

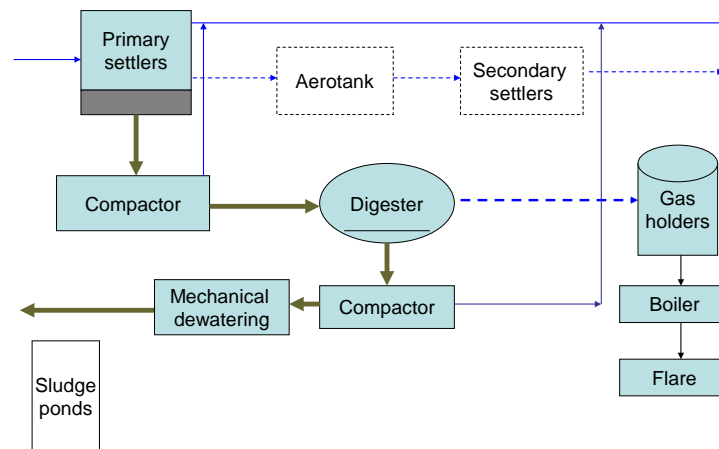

Figure 15: Proposed scheme for the Gardabani WTP

The proposed project activity involves the rehabilitation of the wastewater and sludge treatment branches, i.e. rehabilitation of the aeration tank (the secondary treatment of wastewater) and the methane-tank (digester) for the sludge treatment, completed, in addition, with the installation of units for further utilization of the gas (methane) captured in the digester (cogeneration unit for converting the gas into electricity, flare for combustion of the left-over gas) and compactors for the sludge removed from the primary and secondary treatment.⁵⁶

The Tbilisi City Hall and State authorities should force the distribution companies to develop and implement a “Two-Year Urgent Action Plan” for an initial cut of losses by half and keep them in the frame of 5-10% for the electric network and 3-5% for the natural gas distribution network (normal losses for gas distribution within the city limits are 3-7% if big reservoirs not available). Commercial losses are approximately 5-10% for the electric network and 10-15% for gas distribution in the city of Tbilisi. As a result there is an energy saving potential of 650 million kWh (250 million kWh of electricity and 37 million Nm³ of gas).⁵⁷

5.2. Baseline Emissions Inventory for Waste Water Treatment

GHG Emissions from Waste Water (WW)

GHG emissions from wastewater include methane and N₂O emissions. IPCC Guidelines distinguish domestic and commercial WW and Industrial WW, the former considered being mostly CH₄-containing, and not the latter.

⁵⁶ Gardabani Waste Water Treatment Plant Rehabilitation Project under Clean Development Mechanism, 2006

⁵⁷ Tbilisi City Energy Efficiency Concept Paper, 2008

Methodology for Estimating GHG Emissions

IPCC guidelines provide a methodology for the calculation of methane emissions from WW and N₂O emissions from human sewage. The method is based on the population number and connected to the collector. The only activity data provided by the Ministry of Environment Protection and Natural Resources every year are the Volume of WW and the BOD (biological oxygen demand) contained in it. The measured content of nitrogen is not provided. Thus, according to the data available, just methane emissions can be estimated from the WW.

Methane Emissions

The methodology of the IPCC is not fully suitable in our case to be used directly for the calculation of emissions. It can be used with calculating sheets and modified according to the data at hand. The default values of the parameters provided in the sheets for the CH₄ emission calculation, however, can be used.

Methane emissions are a function of the amount of organic waste (DOC) generated and an emission factor characterizing the extent to which this waste generates CH₄. There are three tier methods for estimating CH₄ from this category. According to the level of the data availability the tier 2 method has been chosen, considering mainly default values with some country-specific data. Methane is calculated for each year with the consideration that all the potential will be realized during the year.

Calculations

The calculation of the CH₄ emission is based on degradable organic matter contained in the WW. This parameter is included as the activity data in the formula (from 2006 IPCC GLs) and subtracted along with sludge removed after the treatment and methane recovered (R) for energy purposes, but these two are not our case: the sludge is left in the ponds and currently no methane recovery takes place in Georgia. So, the calculation is made for the entire inflow – WW and sludge together. The *total organic degradable matter* is calculated as the total amount of BOD (kg) per year. The formula provided by the 2006 IPCC GLs:

$$\text{Emission} = \text{Activity Data (population} \times \text{BOD/cap/year)} \times \text{Emission Factor,}$$

contains population number and BOD per capita for calculation of Activity Data, but in the case of Tbilisi the population covered by the collector is not known and the calculation formula is modified for **Activity Data** according to the data available: BOD concentration (kg/m³) and the Volume of total WW:

$$\text{AD} = \text{BOD/m}^3/\text{year} \times \text{Volume (m}^3\text{)}$$

WW in the Gardabani plant collects the WW from domestic and commercial sources, so the parameter chosen for calculation - Biological Oxygen Demand (BOD), - corresponds to the

recommendation of the GLs for Domestic and Commercial WW, in the opposite of Chemical Oxygen Demand (COD), recommended for Industrial WW.

As the volume of the WW and BOD (at the inlet) are the input parameters for the calculations, they determine the amount of methane potential in the WW; other parameters are taken at default from the 2006 IPCC GLs, taking into consideration country-specific conditions. The data provided to the MEPNR about WW are divided into two sets: 1) the volume of WW collected (provided by the company “Georgian Water and Power”) and 2) volume and BOD of the WW out-flowing from the plant after treatment (provided by the plant itself). Sometimes GWP provides, along with volume, BOD as well. Thus, we can judge about the BOD concentration at the inlet based on these values.

To recover incomplete sets of time-series and deficient parameters, the method of interpolation has been used. Data at the inlet has been recovered according to the proportions between inlet and outlet data, using the figures for the years 2005 and 2008.

The table below is demonstrating the set of the input parameters, used in the calculations of CH₄ potential from the WW.

Years	Volume (Outlet)	Volume (Inlet)	BOD (Outlet)	BOD (Inlet)
2005	80928	208550.00	20	69.0
2006	133662	344443.27	20.98	69.1
2007	137379	354021.87	21.96	72.3
2008	105039	270682.59	24.25	76.0
2009	11800	30408.27	26.8	88.2
2010	11908	30686.59	25.1	82.6

Table 8: Set of activity data, recovered from existing figures.

The figures of the WW volume at the outlet for the last two years show an abrupt decrease due to a crash/disorder of the collector, causing a significant part of the collected WW to by-pass the treatment plant.

Taking into consideration the inappropriateness of the use of the data for the last two years, the assumption was made that the activity data cannot be lower than those of the year 2005, taking into consideration the fact that the collector has been extending from year to year, along with road-repair works, increases in WW, and that its disorder will be stopped in nearest future.

On the basis of these assumptions the figures of WW volume for 2008-2020 were calculated from the average growth of volume of WW till 2008, not taking into consideration the decrease of volume of the WW at the inlet of the Gardabani plant due to the dysfunction of the collector: the assumption was made that it will be repaired and provide the plant with the entire amount

of WW collected in the city. No assumption of any extension of the collector was made, not knowing the plans of the owner-company in the future. The BOD concentration figures for 2011-2020 were taken from the average of the past year. This assumption is conservative.

The **Emission factor** as kg CH₄ per kg BOD is calculated as a product of the parameters Bo (maximum methane producing capacity), MCF (methane conversion factor) and a coefficient T, characterizing the pathway of discharge or degree of treatment utilization (being set to 1 for our case).

$$EF = Bo \times MCF \times T$$

The values for these parameters have been chosen from the default values provided by the GLs, according to the country's specifics. All the EFs are used identically for all the time series.

All the parameters with their chosen values, used in the calculation together with the references, are given below:

#	Parameter/coefficient	value	Description/justification	Reference
Emission factor (EF)				
1.	MCF	0.3	Default value for 'Centralized aerobic treatment plant'	Table 6.3, 2006 IPCC GLs, (2007)
2.	Bo	0.6 kgCH ₄ /kg BOD	Default for domestic WW	Table 6.2, 2006 IPCC GLs, (2007)
3.	T (degree of treatment utilization)	0.90*	Default for Russia, the closest to Georgia's case	Table 6.5, 2006 IPCC GLs, (2007)
4.	EF=Bo x T x MCF			
Activity data (2005)				
5.	BOD concentration	69 kg/m ³	Measured	
6.	Volume of WW (annual)	208,55 mio m ³	Measured	
7.	Correction factor (I) for industrial BOD discharged in sewers	0.125	Default, recommended by the 2006 IPCC GLs for additional industrial BOD discharged into sewers (for collected WW)	Equation 6.3 and further text pp.6.13-6.14
8.	AD=BOD (conc.)xVolume x I			

Table 9: Parameters and logic of calculation of CH₄ emissions from WW. *Can be adjusted

Baseline emissions

The table and the graph for baseline emissions are shown below:

Years	Volume of WW (m3)	BOD Concentration (kg/m3)	Parameter I	Combined EF (0.3*0.6)	Methane Emission (t)	Methane Emissions (t CO2e)
2005	208550.00	69.00*	1.25	0.18	3237.74	67992.5
2006	344443.27	69.07*	1.25	0.18	5352.63	112405.1
2007	354021.87	72.29*	1.25	0.18	5758.46	120927.6
2008	363867.22**	76.00*	1.25	0.18	6222.13	130664.7
2009	373986.37**	88.23*	1.25	0.18	7423.94	155902.7
2010	384386.93**	82.63**	1.25	0.18	7146.38	150074.0
2011	395076.73**	76.2	1.25	0.18	6773.59	142245.4
2012	406063.81**	76.2	1.25	0.18	6961.96	146201.2
2013	417356.45**	76.2	1.25	0.18	7155.58	150267.1
2014	428963.13**	76.2	1.25	0.18	7354.57	154446.0
2015	440892.60**	76.2	1.25	0.18	7559.10	158741.2
2016	453153.82**	76.2	1.25	0.18	7769.32	163155.8
2017	465756.03**	76.2	1.25	0.18	7985.39	167693.1
2018	478708.70**	76.2	1.25	0.18	8207.46	172356.7
2019	492021.59**	76.2	1.25	0.18	8435.71	177149.9
2020	505704.71**	76.2	1.25	0.18	8670.31	182076.5

Table 10: Baseline estimates for CH₄ emissions from WW in the city of Tbilisi. *The real values; an average of them is taken for the rest of BOD concentration); ** The values are projected/corrected under the assumption of growth of the WW volume proportional to the average growth in 2005-2007. This assumption was made in order to get rid of mistakes due to disorders of the collector.

The corresponding graph (emissions in tons CH₄) is shown below:

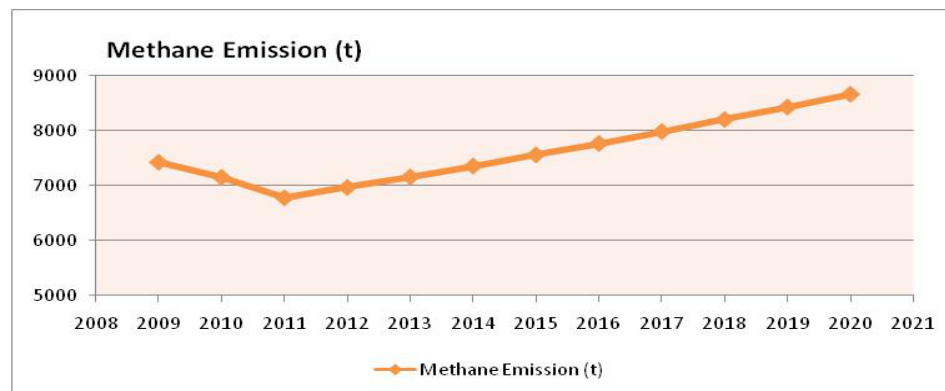

Figure 16: CH₄ emissions in tons

Note: The approach, methodology, data and assumptions for projections can be changed subject to further information availability and plans of the plant-owner company regarding a rehabilitation of the plant.

N₂O emissions from the WW

Only the simplest method is provided by the IPCC GLs for calculation of N₂O emissions: from human sewage only. In the case of the Gardabani WW treatment plant this approach seems inappropriate as the WW treated there contains a significant amount of nitrogen due to the AZOTI-plant effluent. Thus, the suggested formula should not be used.

The N₂O emissions can be calculated only when the concentration of nitrogen is measured in the WW. The laboratory operating at the plant is equipped for conducting BOD concentration measurements only. The possibility of nitrogen measurement on-site is to be explored.

Sum of CH₄ and N₂O emissions (in CO₂ equivalent) will form the total GHG emissions from the WW for Tbilisi-city.

Waste Incineration

Only medical waste is incinerated in Georgia. In the city of Tbilisi the company “Express Diagnostics”, which owns a license for this work, collects biological/medical waste from the hospitals of the city and incinerates it in a special incinerator at a temperature of 300 degrees centigrade. The ashes of the incinerated medical remains are disposed of in the SWDS. This portion is considered there in the ‘Inert’ category.

Waste incineration normally produces 3 GHG gases: CO₂, CH₄ and N₂O. According the IPCC GLs CO₂ is calculated on the base of the fossil-origin carbon content in the waste incinerated; emissions of CH₄ are considered scarce and that of N₂O are calculated according to default values (IPCC Good Practice Guidance). It is a good practice to measure CH₄ and N₂O in the emitted gas (e.g. in Japan’s GHG inventory).

So far we are not aware of the amount of medical waste incinerated annually in Tbilisi. The estimation of the emissions depends (even in the case of using default emission factors) on the extent of accountability of the company and the availability of the data needed for calculations. The estimation of the GHGs from this source of GHG should not be neglected as it has the potential of being recovered for energy purposes, as is done in some countries.

5.3. Action Plan Table for WWT

SECTORS & fields of action	KEY actions/measures per sector/field of action	Responsible Agency	Implementation Period [start & end time]	Estimated costs per action/measure	CO2 eq. reduction target (t/a) in 2020*	Aggregated CO2 eq. reduction in 2020
<i>Waste Water Treatment</i>						163 87*
Action WW1	Overall rehabilitation of the plant to the designed capacity	Economic Policy Agency, Tbilisi City Hall	2012-2020	20 mil USD		
WW1.1	Extension of the collector to the designed capacity					
WW1.2	Rehabilitation of the secondary and tertiary treatment devices and facilities to the extent of operation					
Action WW2	Rehabilitation of the plant secondary treatment facilities (methane-tank, digester), recovery and utilization (self-consumption, sold or flared) of gas	Economic Policy Agency, Tbilisi City Hall	2013-2020	10 mil USD	163.87*	1310950.8*(after 2013)
WW 2.1	Checking and re-construction/rehabilitation of the secondary treatment facilities of the plant (methane-tank, digester, aeration tank),					
WW2.2	Operation of the secondary treatment facilities of the plant					
Total:					163.87*	

*Assumption: efficiency of methane recovery is 90%; **Assumption: new technology has more efficiency.

5.4. Description of Actions

Gardabani wastewater treatment plant has a large potential for GHG reduction through methane and even N₂O recovery. The latter seems a far projection but methane recovery has good chances there. The plant has WW secondary treatment equipment and methane-tanks, designed for methane generation with the further possibility of keeping it in methane-catchers. The measure can include the checking and further rehabilitation (or renovation) of the equipment. Additional profit could be reached from composting the sludge removed in the process of secondary treatment/methane recovery; de-methanized dried masses of sludge can be composted and used in agriculture as nitrogen-containing fertilizer. The amount of methane potential in the WW by now is about 7000 t CH₄ annually, comprising 98,000 t CO₂ eq, i.e CER per year, worth about 12 Euro each in market.

Action WW1 and Action WW2: Rehabilitation of the WW treatment plant -

a) Partial rehabilitation- aimed only at operation of secondary and tertiary treatments; this will require checking of the devices and making decision on reasonability of repairing works compared to renovation (purchasing) of new devices (such as methane tank, aeration system, gas holders), since the plant is old, made by Soviet standards and might complicate the task. The updated plant will provide methane recovery of the WW, as the secondary treatment implies this option. The recovered methane will be held in updated gas-holders and be further used for inner and/or outer purposes; or b) complete rehabilitation- rehabilitation includes full reconstruction of the plant to the designed capacity, entailing the collector; currently, the latter receives only a part of the designed amount of waste water; the measure implies connection of new pipelines to the collector to ensure full designed coverage of the population. This option will require significant finances and some legal/tax support as well.

Action WW2: Renovation of the plant - innovation according to modern standards, purchasing new parts and devices and substituting the obsolete ones. This measure includes purchasing of new, modern devices (digesters, gas holders, aeration system), substituting the old devices of the secondary treatment, that have never worked. This may change the structure of the plant. The measure will result in a new, modern plant with advanced technology, including methane recovery. The recovered methane will be held in new gas-holders, and used or sold. Sludge, removed after the WW treatment, can be composted for use in agriculture as fertilizer or dumped in the landfill.

Measures for emissions reduction from medical waste incineration

Incineration of waste is a significant source of emissions and energy in many advanced countries. In Georgia, waste incineration practice is not common, and nowadays only medical waste is incinerated. In Tbilisi there is a facility for incinerating the remains of all the hospitals of the city. There are some statistics about medical waste generated in Tbilisi (3,379,869 kg annually) but the amount of the incinerated part of it should be adjusted.

Emission reduction from incineration of medical waste should be aimed at the use of the recovered energy in the energy sector. The experiences of other countries should be shared (Switzerland, Turkey). The feasibility of such a measure will depend on the data (medical waste amount, composition, and other physical conditions) and technical parameters of the facility, which are under exploration now.

Box 2: Emissions reduction from medical waste incineration

6. Green Spaces

6.1. Current Situation and Future Trends

In 2009, the Tbilisi City Hall created a special unit dedicated to the greening of the city and the monitoring of ecological environment – the Ecology and Greening Unit. The priorities within this sector were identified and concrete activities were implemented in order to increase the share of green spaces within the built environment, to restore and maintain an ecological balance of green plants and in general, to support a healthy environment in the city.

A decade ago, the environmental situation in the city dramatically changed – forests were cut (including the uncontrolled cutting of trees and fires at Mtatsminda), parks, green squares and historical plants were poorly maintained and in some cases vandalized. The table below presents the overall description of green spaces in Tbilisi by 1999⁵⁸:

Districts	Park, year of establishment	Area (hectares)	population (% from the total)	General Information	
Nadzaladev, Gldani	'Tbilisi Sea' Park	47 (140 initially)		20.2	green area - 39 hectares; roads and squares 7.5 ha; constructions and buildings 2 ha.; green crops are damaged, there is a lack of irrigation water
	Kikvidze Park, 1936	0.11			green area - 9 ha, roads and squares 0.7 ha; construction and buildings - 1.3 ha.
	Avchala Park	3.5			has not been arranged
Didube	Mushtaidi Park and two gardens, 19 th century	4.5 1.7		10.2	green areas - 2.3; construction and buildings 2.6; is overloaded
Mtatsminda	Mtatsminda Park 1938	1.16		9.2	green areas - 2.3 ha; roads and squares 1.6 ha; construction and buildings 2 ha; crops are old, diseased, there is no irrigation water
	Vera (1898) and the 9 th of April Parks (1865-81)	17.5			is densely occupied, overloaded, especially in summer

⁵⁸ Data Source: Tbilisi City Municipality. http://www.ceroi.net/reports/tbilisi/issues/green_areas/parks.htm

Vake, Saburtalo	Vake Park, 1945	0.35		0.2	green areas - 29 ha, roads and squares 6 ha, construction and buildings 0.2 ha; irrigation system (1945) is obsolete; the adjacent territory is close to nature, is convenient by location, is one of the favorite resort places; at present undesirable construction processes are going on; includes Kus Tba and the Open Air Museum
	Lisi Lake Park	0.6			green area - 49.5 ha, roads and squares 10 ha, construction and buildings 0.5 ha.; irrigation system needs reconstruction; due to the lowering of the lake level 40-50 year old trees have desicated; is a popular place because of the existence of the lake.

Table 11: Green areas in Tbilisi. 1999

The rehabilitation and development of green spaces turned into an essential need and as a result, became one of the directions of priority for the Tbilisi City Hall – 56,000 types of coniferous and deciduous trees were planted in the framework of the project “Plant a Tree, Green the City”, and around 100 green spaces were created or rehabilitated. In 3 years time, 150,000 green plants will be planted in different areas of the city. Chapter VI- Landscape Environment and Development of the Strategic Plan of Tbilisi lists the priorities within this sector.



Picture 10: “Plant a Tree, Green the City” project

One of the objectives of the Unit is to create “environmental islands” where citizens will be able to take short breaks during busy work days, to avoid hot summer days while staying in the capital, to take kids outside, etc. It should be mentioned that during the last year, 30 squares were reconstructed, recreational zones were greened and arranged according to modern standards, and a flower clock and vertical garden were created. The future plans are even more ambitious – it is

planned to combine the Mziuri Park with the Tbilisi Zoo and create one massive green area in the centre of the city. The space will be provided with all necessary facilities to attract people of all ages.

Greening of Tbilisi suburb areas has been launched too – territories around new and closed landfills, Gldani neighbourhood, and the University upper building territories (90,000 ha in total) will be greened and covered by forests and parks. These areas that were polluted by municipal or construction waste will be cleaned and covered by 10,000 units of trees/plants.

It is equally important to maintain already existing forests and parks. In October 2010 the City Council made the decision that all forests around and within the city, 8106.9 ha in total, would be administered by the city and receive the status of landscape-recreational areas. More green areas will be passed to the city administration in the coming future.

In 2011 the Ecology and Greening Unit plans to rehabilitate and develop the Khudadovi Forest at 3, ha area. Later, the territory will be further expanded (63.5.ha). Control mechanisms will become stricter in order to avoid any construction activities on green territories, leasing or renting out of the forest areas, or the clear-cutting of woods.

In the Table presented below, the trees/plants that will be planted in Tbilisi in 2011 are listed. In total, 11,400 units of trees/plants will be planted:

Type of Tree/Plant	Time needed for full growth (years)	Height (Min/Max)	Number	Potential to grow in 1 year (in %)
Cypress (Cupressus)	5-6	150cm/250cm	1500 (pyramidalis - 1000; horizontalis-500)	90
Cedar (Cedrus atlantica, "C.libani")	5-6	100cm/150cm	500	85
Poplar (Populus italic "P.Pyramidalis")	5-6	150cm/250cm	1000	90
Common Ash (Fraxinus excelsior)	5-6	150cm/250cm	1000	90
Maple (Acer)	5-6	150cm/250cm	500	90
Linden (Tilia Caucasica)	5-6	150cm/250cm	1000	90
Pine (Pinus)	5-6	90cm/140cm	1000	90

Laurestine (<i>Viburnum tinus</i> eve prince)	3-4	70cm/100cm	300	85
Wintercreeper (<i>Euonymus fortunei</i> "vegetus")	5-6	50cm/100cm	400	85
Ligustrum	5-6	70cm/120cm	1500	85
Thuja	5-6	70cm/120cm	1500	85
Crape myrtle (<i>lagerstroemia indica</i>)	5-6	160cm/180cm	50	90
Olender	5-6	100cm/150cm	1000	85
Katalpa	5-6	200cm/250cm	150	85

These listed actions will improve the functioning of the eco-systems of the city and will restore the ecological balance that had been in decline a decade ago.

6.2. Baseline Emissions Inventory for Green Spaces

Methodology

The **CO2FIX V 3.1 model** was used to calculate CO₂ emission sequestration and carbon stocks as a result of reforestation and afforestation. The model CO2FIX V 3.1 estimates carbon stocks and the amount of sequestered emissions by means of the **Carbon Accounting** method. The coefficients and data required by the model to make estimations were obtained from the Tbilisi City Hall.

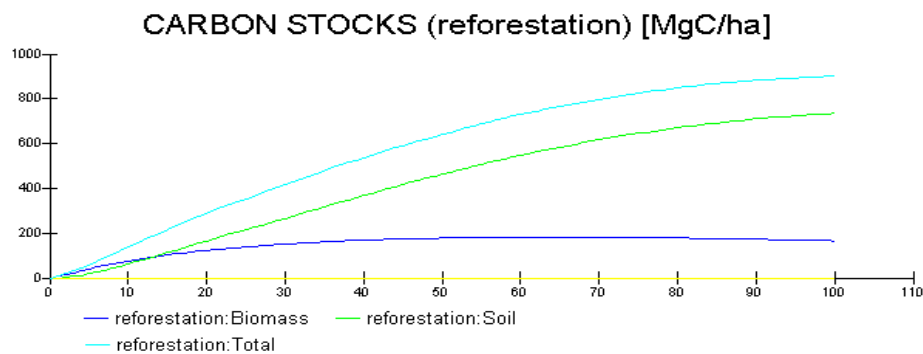

Figure 17: Estimated carbon stock dynamics from 1 ha trees/plants throughout the years

Table 1 below shows the amount of sequestered carbon and CO₂ by reforestation per one hectare according to calculations done by the model (the model calculates only per one hectare):

	Sequestered Carbon reforestation	Sequestered Carbon reforestation		Sequestered Carbon reforestation	Sequestered Carbon reforestation		Sequestered Carbon reforestation	Sequestered Carbon reforestation		Sequestered Carbon reforestation	Sequestered Carbon reforestation
year [yr]	carbon [MgC/ha]	CO2 equiv. [MgCO2equi...]	year [yr]	carbon [MgC/ha]	CO2 equiv. [MgCO2equi...]	year [yr]	carbon [MgC/ha]	CO2 equiv. [MgCO2equi...]	year [yr]	carbon [MgC/ha]	CO2 equiv. [MgCO2equi...]
0	0.00	0.00	26	366.33	1343.20	52	659.87	2419.52	78	839.71	3078.95
1	8.19	30.03	27	378.79	1388.88	53	669.28	2454.03	79	844.19	3095.35
2	18.21	66.76	28	391.28	1434.69	54	678.59	2488.15	80	848.51	3111.19
3	30.18	110.68	29	403.81	1480.62	55	687.78	2521.87	81	852.67	3126.44
4	43.68	160.17	30	416.37	1526.68	56	696.72	2554.64	82	856.67	3141.13
5	58.86	215.82	31	428.92	1572.72	57	705.40	2586.47	83	860.53	3155.26
6	74.41	272.84	32	441.47	1618.71	58	713.83	2617.36	84	864.23	3168.85
7	90.18	330.66	33	453.99	1664.63	59	722.01	2647.37	85	867.80	3181.93
8	106.01	388.71	34	466.49	1710.47	60	729.96	2676.52	86	871.16	3194.25
9	121.87	446.86	35	478.96	1756.20	61	737.69	2704.87	87	874.32	3205.85
10	137.70	504.90	36	491.20	1801.07	62	745.21	2732.43	88	877.29	3216.73
11	153.48	562.75	37	503.20	1845.08	63	752.52	2759.25	89	880.07	3226.92
12	169.19	620.36	38	514.97	1888.22	64	759.64	2785.33	90	882.67	3236.45
13	184.84	677.74	39	526.51	1930.53	65	766.56	2810.72	91	885.10	3245.36
14	200.42	734.89	40	537.82	1972.02	66	773.27	2835.34	92	887.37	3253.68
15	215.95	791.81	41	548.91	2012.67	67	779.78	2859.21	93	889.48	3261.43
16	231.13	847.46	42	559.77	2052.50	68	786.09	2882.34	94	891.45	3268.66
17	245.97	901.89	43	570.42	2091.55	69	792.21	2904.76	95	893.28	3275.37
18	260.49	955.15	44	580.87	2129.84	70	798.13	2926.49	96	895.02	3281.73
19	274.73	1007.36	45	591.12	2167.42	71	803.89	2947.60	97	896.66	3287.75
20	288.71	1058.60	46	601.24	2204.56	72	809.49	2968.11	98	898.21	3293.45
21	302.34	1108.59	47	611.26	2241.29	73	814.92	2988.04	99	899.68	3298.84
22	315.66	1157.40	48	621.18	2277.65	74	820.20	3007.40	100	901.07	3303.92
23	328.67	1205.11	49	631.00	2313.65	75	825.33	3026.21			
24	341.40	1251.79	50	640.72	2349.32	76	830.29	3044.40			
25	353.87	1297.54	51	650.35	2384.61	77	835.08	3061.97			

Table 12: Amount of sequestered carbon and CO₂ per one hectare

Projection

In 2011, the Tbilisi City Hall plans to plant seven hectares of different types of trees/plants. According to the results presented in Table 1, in ten years timeframe **963.9 tons of carbon** will be stocked and **3534.3 tons** of CO₂ will be sequestered as a result of a 7 ha reforestation.

YEAR	Carbon Stocks C/ton	CO ₂ sequestration/ton
2015	412.02	1510.74
2020	963.9	3534.3
2030	2020.97	7410.2
2040	2914.59	11009.04
2050	3764.74	13804.14

Table 13: Carbon stocks and sequestered CO₂ in Tbilisi by 7 ha trees/plants

6.3. The Action Plan Table for Green Spaces

SECTORS & fields of action	KEY actions/measures per sectors/field of action	Responsible Agency	Implementation Period [start & end time]	Estimated costs per action/measure	Expected CO2 reduction per measure [thsnd/t] in 2020	CO2 reduction target per sector [t] in 2020
<i>Green Spaces</i>						3534.3
Action P1:	Development of Green Spaces	Economic Policy Agency, Tbilisi City Hall				
P1.1	Creation of “environmental islands”		2012-2020			
P1.2	Conjunction of Mziuri and Tbilisi Zoo		2013-2016			
P1.3	Khudadovi forest reforestation (63, 5 ha)		2014-2018			
P1.4	Turtle Lake area reforestation (29,2 ha)		2015-2020			
Action P2:	Planting trees/plants	Economic Policy Agency, Tbilisi City Hall				
P2.1	150,000 green plants		2012-2015			
P2.2	10,000 trees/plants		2012-2013			
P2.3	11,400 tree/plants (including 3 ha of Khudadovi Forest)		2011		3534.3	
Action P3:	Improved administration and regulation	Economic Policy Agency, Tbilisi City Hall				
P3.1	Forests under Tbilisi City Hall administration		2012-2015			
P3.2	Stricter regulations for green areas		2012-2013			
Total:					3534.3	

6.4. Description of Actions

Action P1: Development of Green Spaces

P1.1- Creation of “Environmental Islands”: green spaces in the centre of the city where citizens will be able to take short breaks during busy working days, avoid hot summer days while staying in the capital, to take kids outside, etc.

P1.2 - Conjunction of Mziuri and Tbilisi Zoo: the Mziuri Park will be united with the Tbilisi Zoo and one massive green area in the centre of the city will be created.

P1.3 - Khudadovi Forest: to rehabilitate and develop the Khudadovi Forest to a 66.5 ha area in total (3 hectares in 2011)

P1.4 - Turtle Lake Area: 29.2 ha of forest will be rehabilitated

Action P2: Planting Trees/Plants

P2.1- 150,000 Green Plants: In three-years time, 150,000 green plants will be planted in different areas of the city

P2.2 - 10,000 Units of Trees/Plants: The greening of Tbilisi suburban areas has been launched too – territories around new and closed landfills, Gldani neighborhood and the University upper building territories (90,000 ha in total) will be greened and covered by forests and parks. The areas that were polluted by municipal or construction waste will be cleaned and covered by 10,000 units of trees/plants.

P2.3 - 11,400 Units of Trees/Plants: 11,400 units of trees/plants of 14 different types will be planted throughout the city

Action P3 - Improved Administration and Regulation

P3.1 - Forests under Tbilisi City Hall Administration: Forests around the city will be under the city administration

P3.2 - Stricter Regulations for Green Areas: Control mechanisms will become stricter in order to avoid any construction activities on green territories, leasing or renting out the forests, clear-cutting of woods. More green areas will be passed to the city administration in the coming future.

7. Electricity Distribution⁵⁹

The energy in Tbilisi is distributed by JSC Telasi. According to data provided by the distribution company the company had 12,4% of electricity losses in 2008.⁶⁰

The Article 15 of the Chapter VIII of the Strategic Plan of Tbilisi covers the actions the capital plans to implement in the sector of electric power distribution. Namely,

- To transfer from existing 6kW to 10 kW distribution network that will increase the efficiency of network by one and a half and reduce electricity losses by two. The capacity of central distribution points will be increased from 8 MW to 12 MW;
- To transfer from existing 35 kW to 110kW distribution network;
- etc.

8. Gas Distribution⁶¹

In Tbilisi natural gas is distributed by the Ltd Kaztransgas. This company also serve Tkneti, Okrokana and Digomi regions. Like electrical energy distribution network losses, there are a lot of losses in natural gas distribution.⁶²

According to the Strategic Plan of Tbilisi (article 18; chapter VIII) , the low pressure gas distribution system will be changed by medium pressure gas distribution network that will considerably support reduction of gas leaks.

⁵⁹ Detailed description of current situation in electricity distribution sector and action plan will be provided in the final document of SEAP

⁶⁰ Tbilisi City Hall Energy Efficiency Concept Paper. 2008

⁶¹ Detailed description of current situation in gas distribution sector and action plan will be provided in the final document of SEAP

⁶² Tbilisi City Hall Energy Efficiency Concept Paper. 2008